

Custom Design Clutches and Brakes

Design Features

Versatility and Flexibility

Armature

Fluted and segmented. Designed as a cooling device to dissipate maximum heat and increase life.

Bushings

Standard industry bushings are used in all the larger sizes to meet your shaft size requirement. Several bore sizes are available as standard in each of the smaller models.

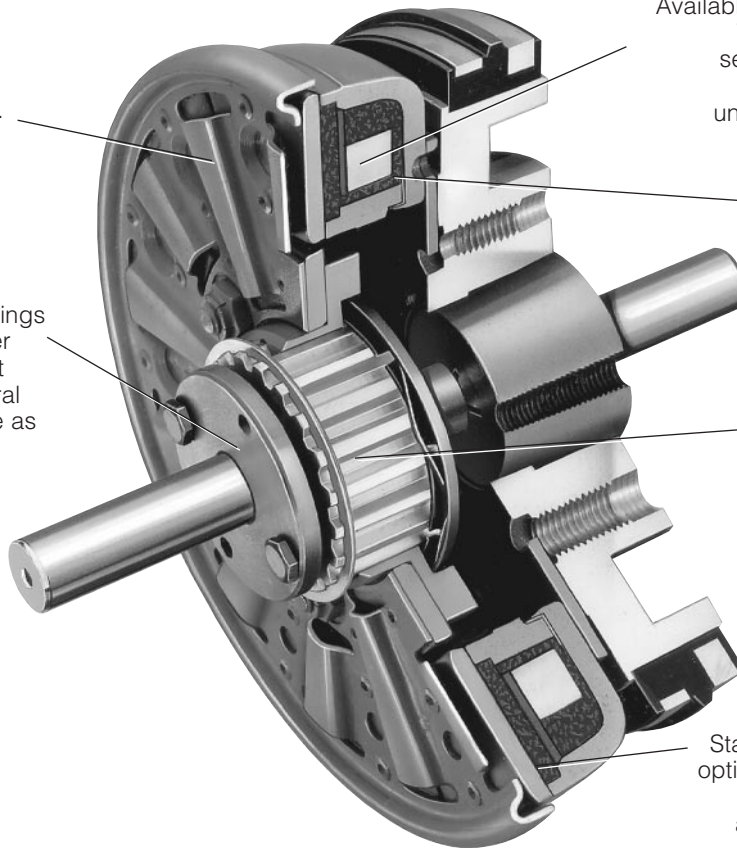

Coil

Available in various voltages for each model. Warner Electric controls (see controls section) provide optimum performance and controllability. All Warner Electric units are either UL listed or recognized. All are CSA certified.

Magnet or Field

Brake magnet mounts to any machine member. Warner Electric clutches are available in flange mount or bearing mount designs.

Armature Drives

Heavy duty spline drive absorbs shock. Rugged, long life materials used in outer and inner spline members. Pin drive design available for normal, lighter duty applications. Anti-backlash armatures available for sizes 170, 250, and 400.

Friction Material

Standard friction material represents the optimum in high torque performance and long life. Long wearing LK facing is available in the larger models to meet application requirements where exceedingly long life is a critical design factor.

Custom design brakes and clutches are user assembled from standard components for optimum performance in the smallest possible package size.

- Easily adaptable to any mounting requirement
- Low initial cost
- Wide range of models and options
- 10 sizes from 1-1/4" to 15-1/4" diameter
- 45 models of clutches, brakes and motor brakes
- Torque range: 5 lb.in. to 1350 lb. ft.
- Horsepower capability to 100 HP

Wide range of sizes

Assembled around the basic components of an electric clutch-brake, magnet and armature. Custom design products come in a tremendous range of sizes, torque ratings and configurations.

LK friction material

Warner Electric offers a special low coefficient (LK) friction material for many standard clutches and brakes. Since two friction materials are available, a comparison of LK to standard is in order.

Since LK has a lower coefficient of friction, lower torque capability results. With LK facing, static torque capacity is only about 60% of catalog rating for any given size. So if a specific size clutch or brake is chosen for its rated torque capacity and LK facings are substituted for standard, a larger size unit will be needed to provide the same torque.

If lower torque ratings can be considered a disadvantage, what are the advantages of LK material? The first is longer life. An ideal situation for LK use is a constant slip application which requires a large unit for high heat dissipation. Another feature of LK is "softer" pickup. Since more slippage will occur,

engagement time is increased and shock is reduced. LK material will also reduce engagement noise, so it can be successfully employed where high noise levels are a problem. It is the standard facing in all tension brakes and motor brake magnets.

For more information on LK facing, see page 232.

Two clutch designs

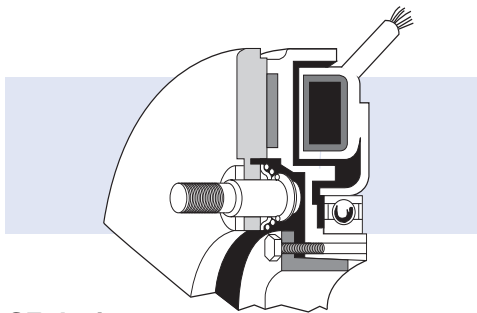

SF design Stationary Field Clutches

The SF design eliminates collector rings and brush holder. Ideal for adverse environmental conditions. Mounting tolerances are generally more critical than the PC design.

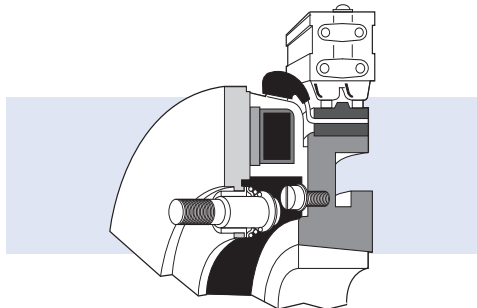

PC design Primary style clutches

Current is carried through brushes and the collector ring to the rotating magnet. The PC design is less expensive than the SF design.

Antibacklash Armature

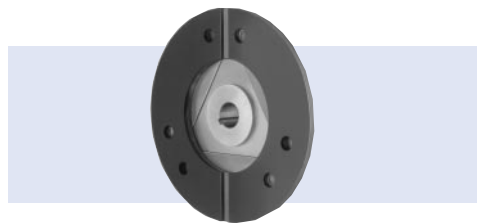

Warner Electric's spring-mounted antibacklash armature design, initially introduced for use in high-cycle-rate applications, is now available for sizes **120, 170, 250, and 400** for general performance applications.

Here are some of their performance features:

- **Zero Backlash**

All backlash, or play, inherent in other armature designs is eliminated. Torque is transmitted through leaf springs which are riveted solidly to armature and hub.

Antibacklash Armature

- **Positive Disengagement**

The leaf springs which attach armature to hub pull the armature back sharply when the coil is deenergized, providing positive disengagement. Wear, heat, and noise caused by dragging armatures are eliminated.

- **Bi-Directional Operation**

Will operate equally well in both clockwise and counterclockwise directions.

- **Low Engagement Noise**

Leaf spring design isolates armature engagement vibration, effectively dampening engagement noise.

- **High Cycle Rate Capabilities**

Makes these armatures suitable for computer and business machine applications and other uses which require high cycle rates for extended periods.

- **Slotted Armatures for Greater Torque Stability**

Friction faces can withstand heat inputs without distortion.

Dimensions, part numbers, and specifications are listed in product descriptions for sizes **120, 170, 250** and **400** clutches and brakes.

Autogap™ System

The Autogap is a system designed to separate the armature from the friction face. This spacing is automatic and occurs prior to total magnetic decay, effectively eliminating noise by preventing drag.

In Normal Duty units the autogap is incorporated as part of the drive pin assembly. In Heavy Duty units the autogap is incorporated as part of the armature/splined hub assembly.

The key advantage that the Warner Electric autogap system provides is automatic adjustment for wear, ensuring that the air gap between friction faces is the same throughout the life of the clutch or brake. This in turn provides:

- Consistent torque throughout the life of the unit
- Consistent engagement time throughout the life of the unit
- Freedom from maintenance adjustment.

For more detail on autogaps, see page 231.

Normal duty vs. Heavy duty armature drives

Normal Duty

Torque is transmitted through three or four drive pins. Proven standard of the industry for all normal duty applications. Standard on clutches, brakes, motor brakes and clutch-brakes, size 500 to 1525.

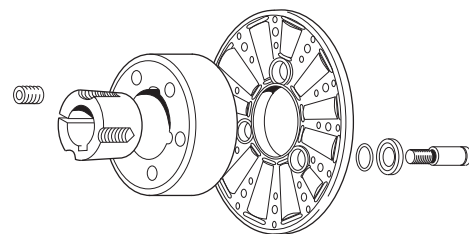

Heavy Duty Drive

Torque is transmitted through a rugged splined hub to a mating splined adapter bolted to the armature. Designed for heavy cycle duty and shock loading applications. Standard on clutch couplings, clutch-brake couplings and Electro-Packs. Optional on brakes and clutches size 500 to 1525.

