

Motor Brake

Heavy Duty

MB-1000 Flange Mounted

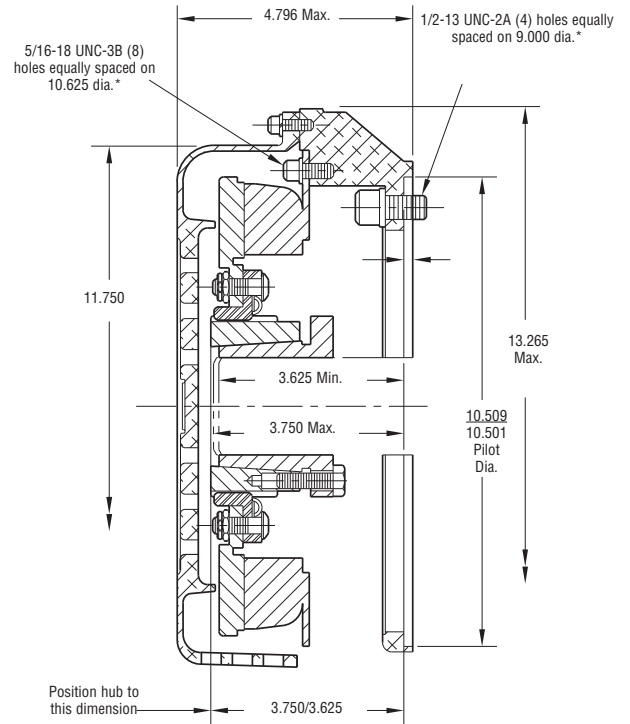
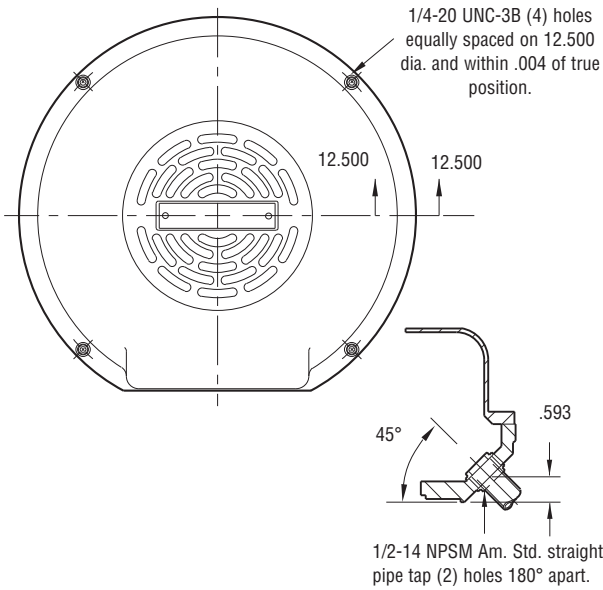

Installation

* Mounting holes are within .006 of true position.

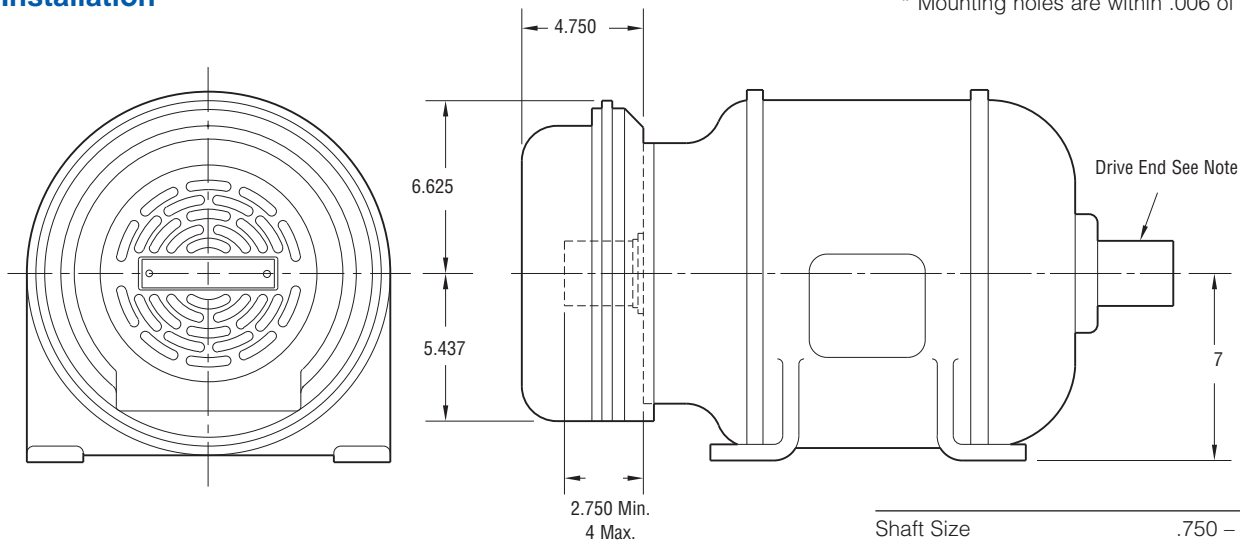

Shaft Size	.750 – 2.687
Static Torque	160 lb. ft.
Maximum Speed	3,600 rpm
Standard Voltage	D.C. 90

All dimensions are nominal unless otherwise noted.

Information on inertia and weights begins on page 239. Coil data is on pages 250 and 251.



Drawing I-25595

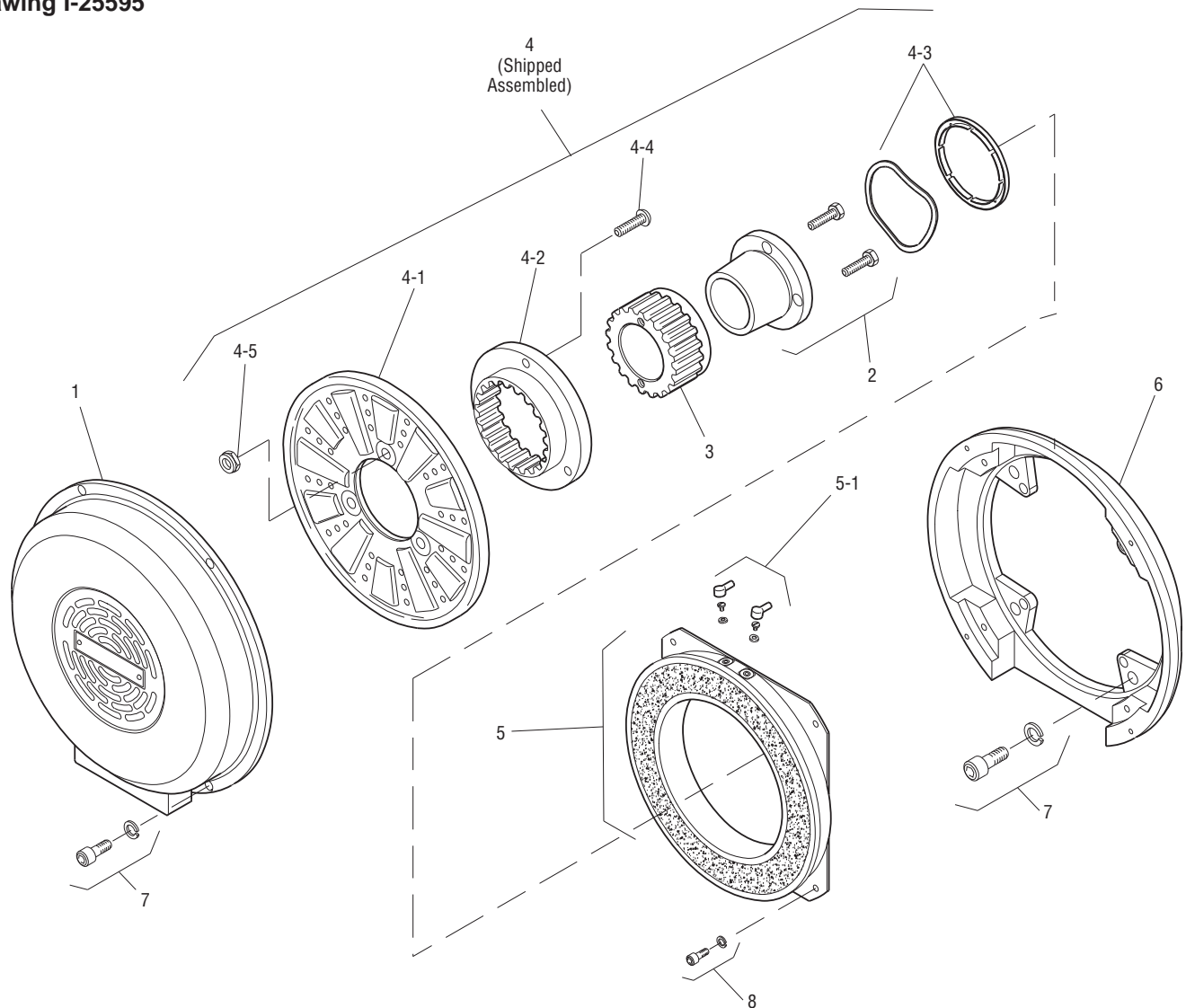

Item	Description	Part Number	Qty.
1	Cover	5352-288-001	1
2	Bushing*	180-0026 to 180-0057	1
3	Armature Hub	540-0062	1
4	Armature Assembly	5322-111-002	1
4-1	Armature	5322-111-036	1
4-2	Splined Adapter	104-0009	1
4-3	Autogap Accessory	5322-101-004	1
4-4	Screw	797-0272	3
4-5	Locknut	661-0004	3
5	Magnet	5352-631-001	1
5-1	Terminal Accessory	5311-101-001	1
6	Adapter	5352-105-001	1
7	Mounting Accessory	5351-101-003	2
8	Mounting Accessory	5321-101-002	1

How to Order:

1. MB-1000 Adapts to NEMA C Face, Double Shaft Motors, Frame Sizes 284 UC and 286 UC.
2. Specify Bore Size for Item 4. (Frame size determines bore).
3. See Controls Section.

Example:

MB-1000 Motor Brake per I-25595 - 90 Volt, 1-3/8" Bore
 These units meet the standards of UL508 and are listed under guide card #NMTR2, file #59164. These units are CSA certified under file #LR11543.

*See page 252 for specific part numbers.

Refer to Service Manual P-208.