

# Motor Brake

# Heavy Duty

## MB-1225 Flange Mounted

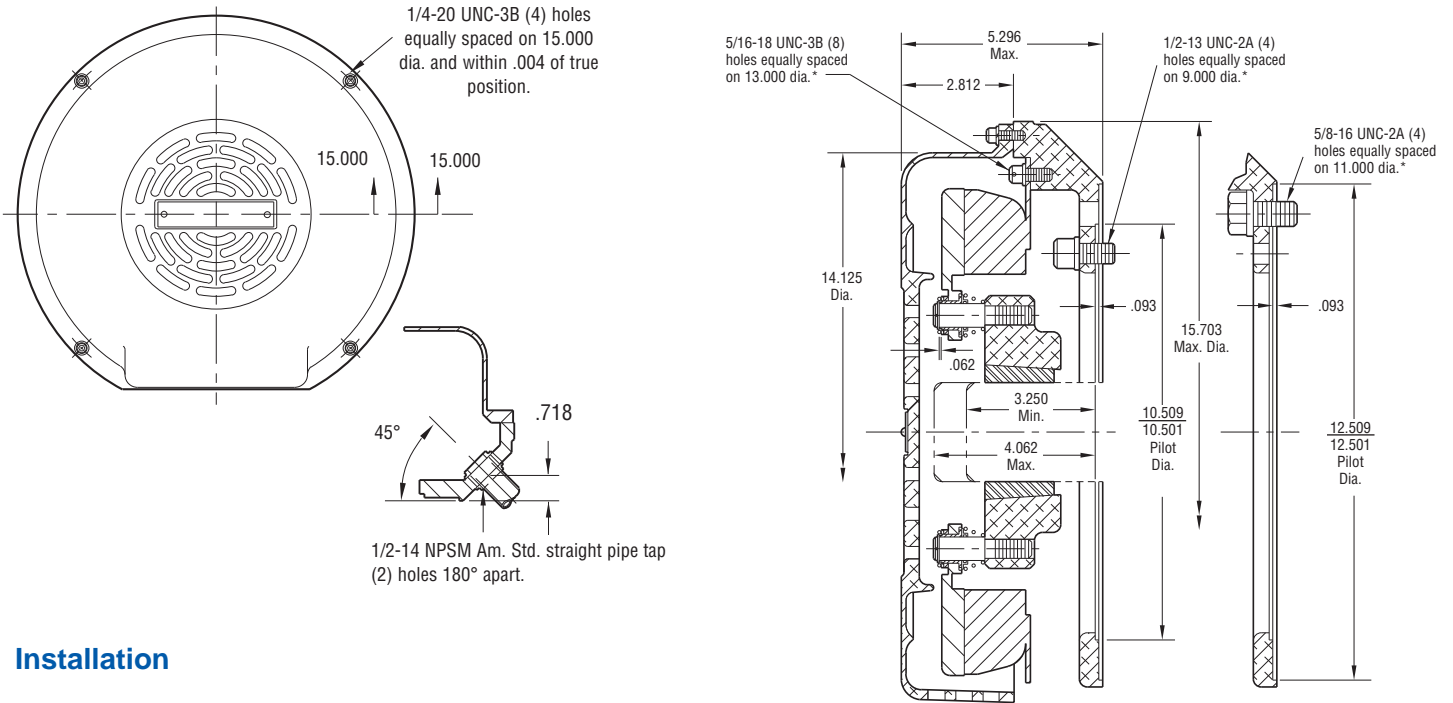

## Installation

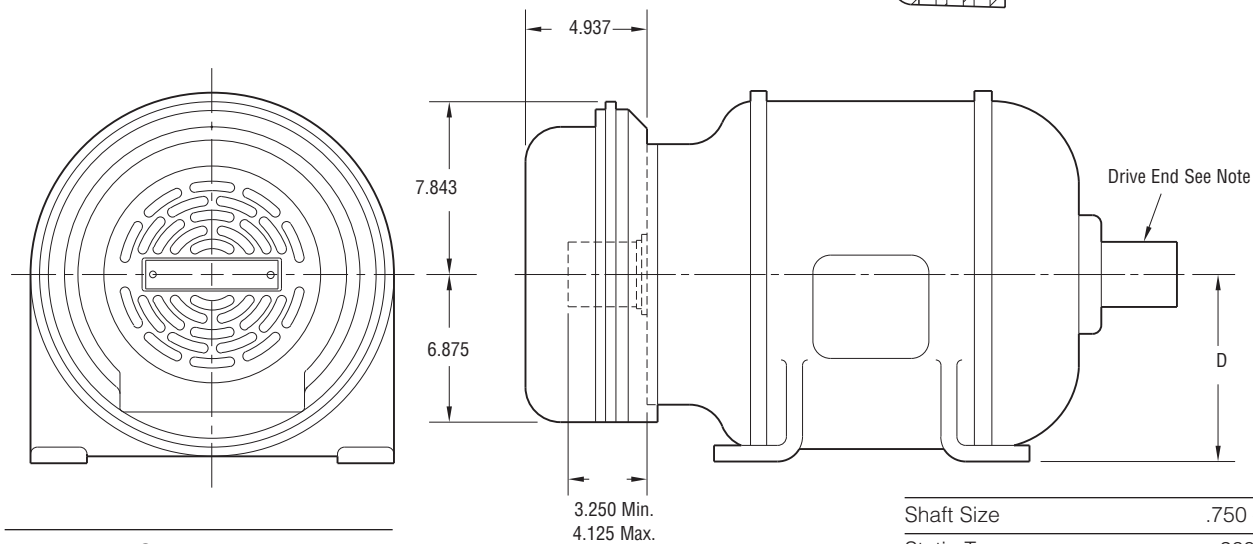

| NEMA Frame Sizes  | Dim. D |
|-------------------|--------|
| 284C & 286C or TC | 7      |
| 324C & 326C or TC | 8      |
| 364C & 365C or TC | 9      |

|                  |              |
|------------------|--------------|
| Shaft Size       | .750 – 2.687 |
| Static Torque    | 260 lb. ft.  |
| Maximum Speed    | 3,000 rpm    |
| Standard Voltage | D.C. 90      |



All dimensions are nominal unless otherwise noted.

Information on inertia and weights begins on page 239. Coil data is on pages 250 and 251.

Drawing I-25618

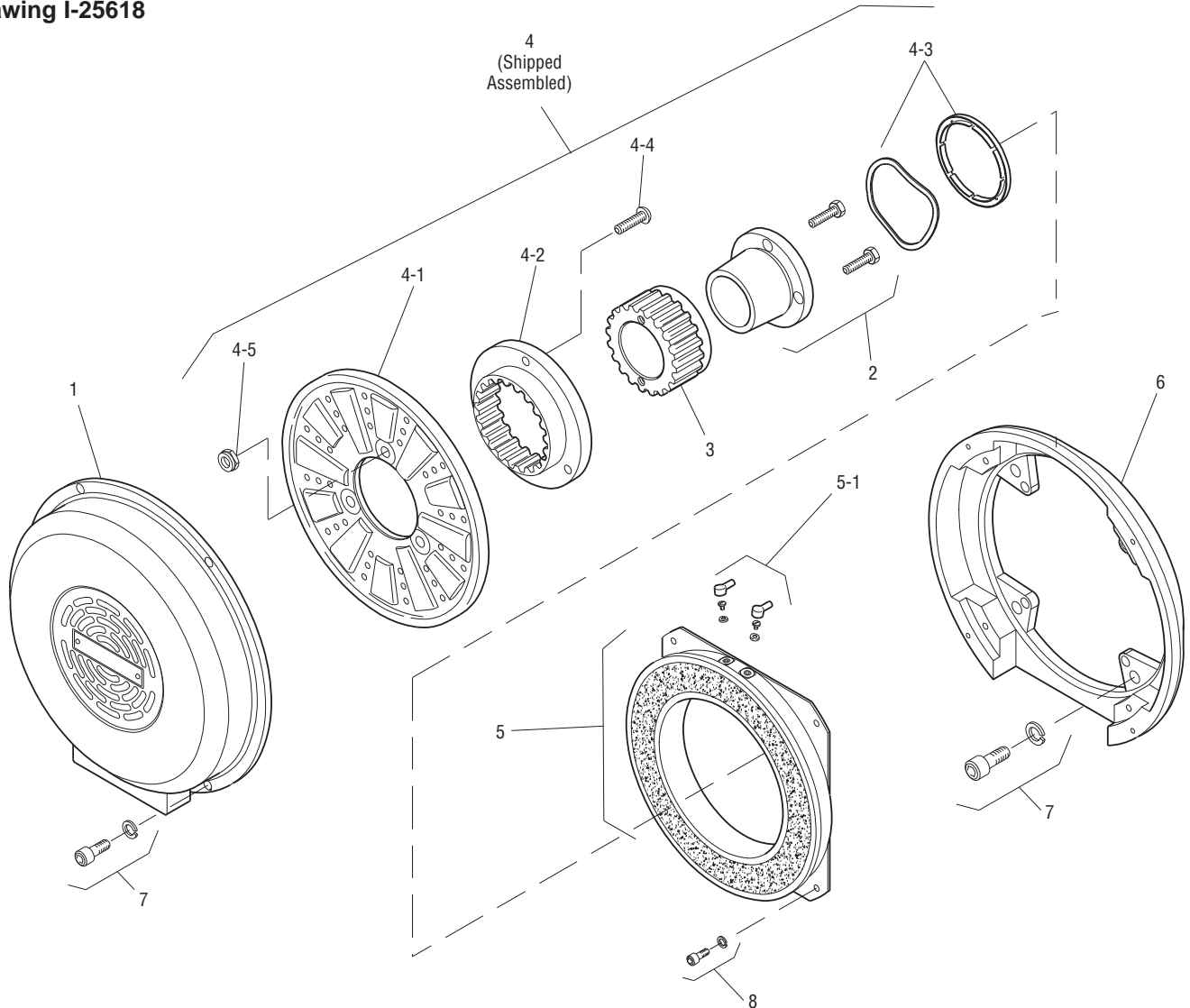

| Item | Description           | Part Number          | Qty. |
|------|-----------------------|----------------------|------|
| 1    | Cover                 | 5353-288-001         | 1    |
| 2    | Bushing*              |                      | 1    |
|      | 3/4" to 2-11/16" Bore | 180-0026 to 180-0057 |      |
| 3    | Armature Hub          | 540-0064             | 1    |
| 4    | Armature Assembly     | 5323-111-001         | 1    |
| 4-1  | Armature              | 5323-111-034         | 1    |
| 4-2  | Splined Adapter       | 104-0010             | 1    |
| 4-3  | Autogap Accessory     | 5323-101-002         | 1    |
| 4-4  | Screw                 | 797-0281             | 4    |
| 4-5  | Locknut               | 661-0005             | 4    |
| 5    | Magnet                | 5353-631-001         | 1    |
| 5-1  | Terminal Accessory    | 5311-101-001         | 1    |
| 6    | Adapter               | 5353-105-002         | 1    |
| 7    | Mounting Accessory    | 5351-101-003         | 2    |
| 8    | Mounting Accessory    | 5321-101-002         | 1    |

### How to Order:

1. MB-1225 Adapts to NEMA C Face, Double Shaft Motors, Frame Sizes 284, 284 UC, 324 UC, 326 UC, 364 UC and 365 UC.
2. Specify Bore Size for Item 2. (Frame size determines bore).
3. See Controls Section.

### Example:

MB-1225 Motor Brake per I-25618 - 90 Volt, 1-5/8" Bore  
 These units meet the standards of UL508 and are listed under guide card #NMTR2, file #59164. These units are CSA certified under file #LR11543.

\*See page 252 for specific part numbers.

Refer to Service Manual P-208.