

Motor Brake

Normal Duty

MB-825 Flange Mounted

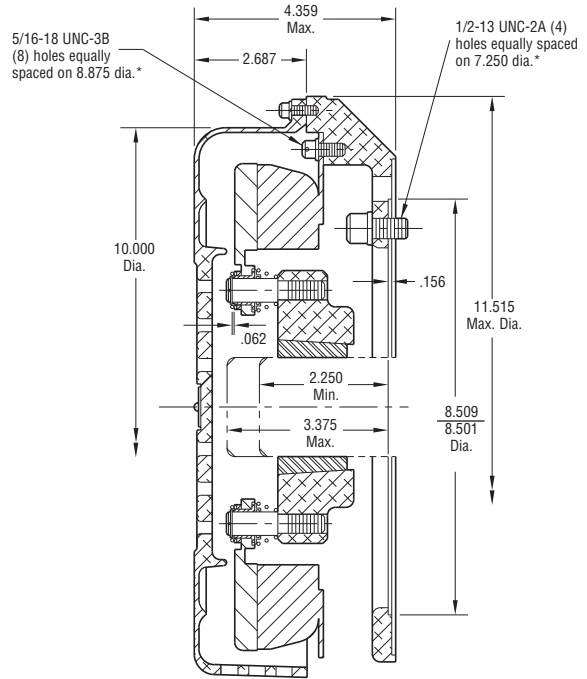
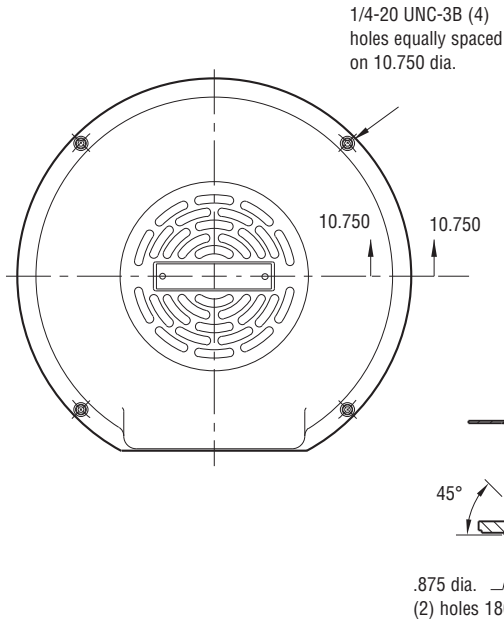

Installation

* Mounting holes are within .006 of true position.

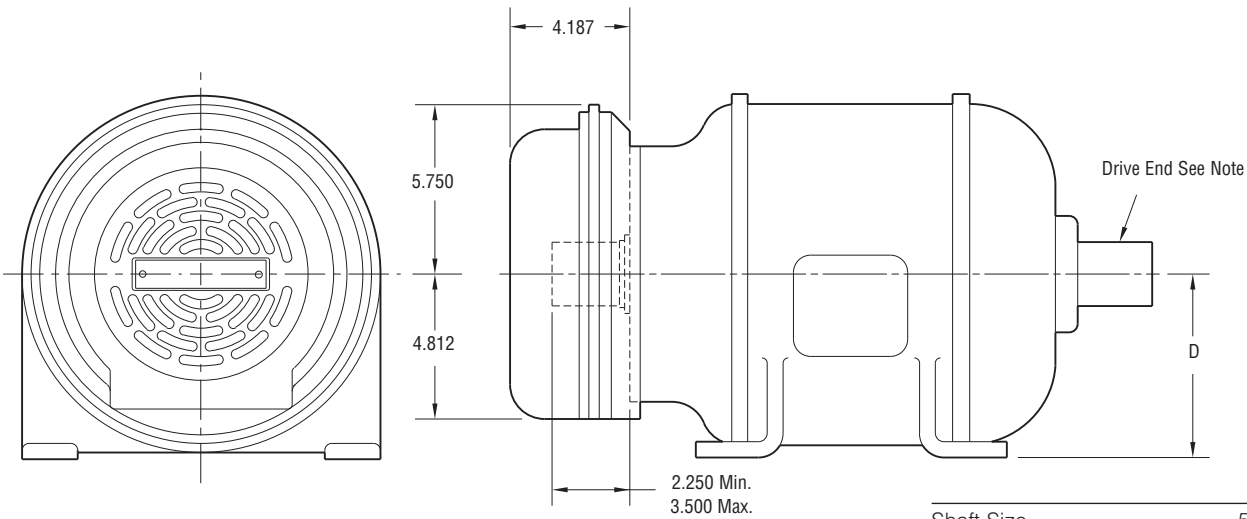

NEMA Frame Sizes	Dim. D
213C & 215C or TC	5.250
254C & 256C or TC	6.250

Shaft Size	.500 – 1.625
Static Torque	80 lb. ft.
Maximum Speed	4,000 rpm
Standard Voltage	D.C. 90



All dimensions are nominal unless otherwise noted.

Information on inertia and weights begins on page 239. Coil data is on pages 250 and 251.

Drawing I-25572

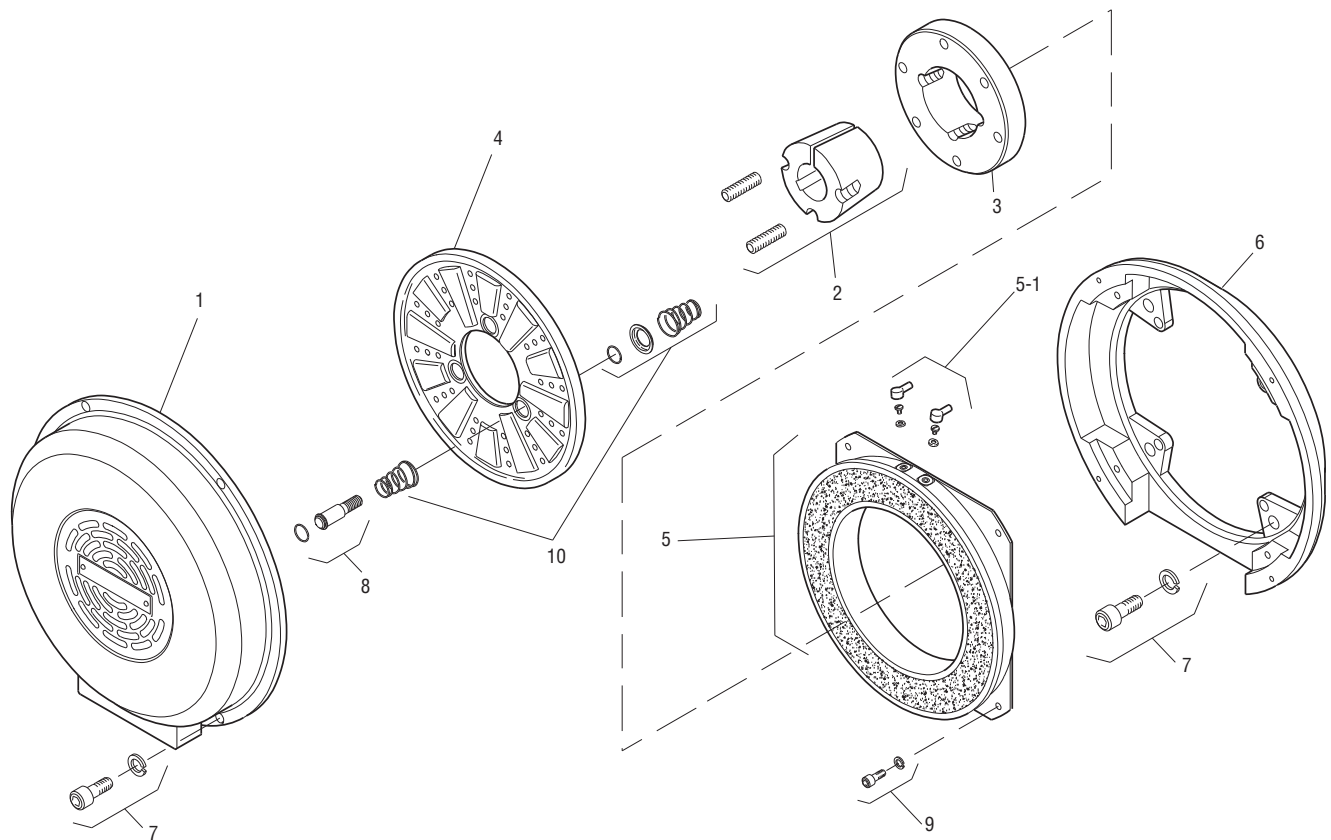

Item	Description	Part Number	Qty.
1	Cover	5351-288-001	1
2	Bushing*		1
	1/2" to 1-5/8" Bore	180-0131 to 180-0149	
3	Armature Hub	540-0394	1
4	Armature	5301-111-018	1
5	Magnet - 90 Volt	5351-631-001	1
5-1	Terminal Accessory	5311-101-001	1
6	Adapter	5351-105-001	1
7	Mounting Accessory	5351-101-003	1
8	Drive Pin and Retainer	5301-101-001	3
9	Mounting Accessory	5321-101-002	1
10	Spring Accessory	5301-101-014	3

How to Order:

1. MB-825 Adapts to NEMA C Face, Double Shaft Motors, Frame Sizes 213 C, 215 C, 254 UC and 256 UC.
2. Specify Bore Size for Item 2. (Frame size determines bore).
3. See Controls Section.

Example:

MB-825 Motor Brake per I-25572 - 90 Volt, 7/8" Bore

These units meet the standards of UL508 and are listed under guide card #NMTR2, file #59164. These units are CSA certified under file #LR11543.

*See page 252 for specific part numbers.

Refer to Service Manual P-208.

Motor Brake

Heavy Duty

MB-825 Flange Mounted

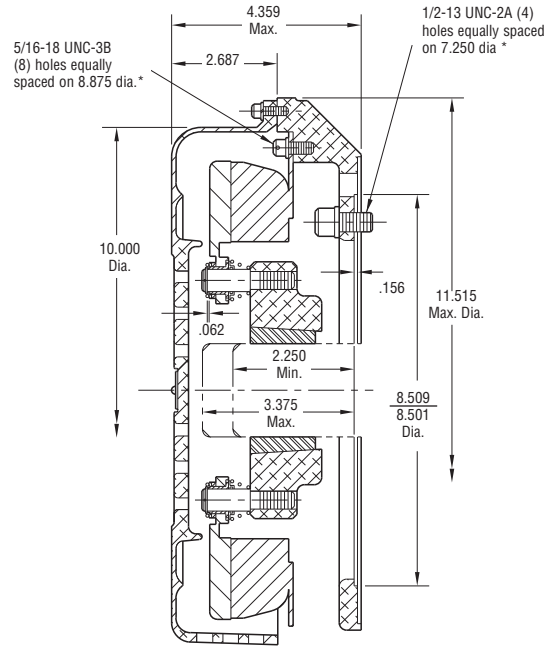
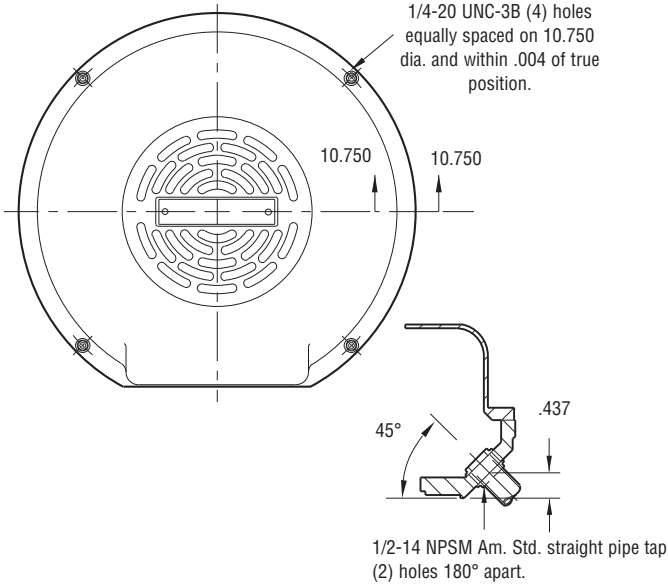

* Mounting holes are within .006 of true position.

Installation

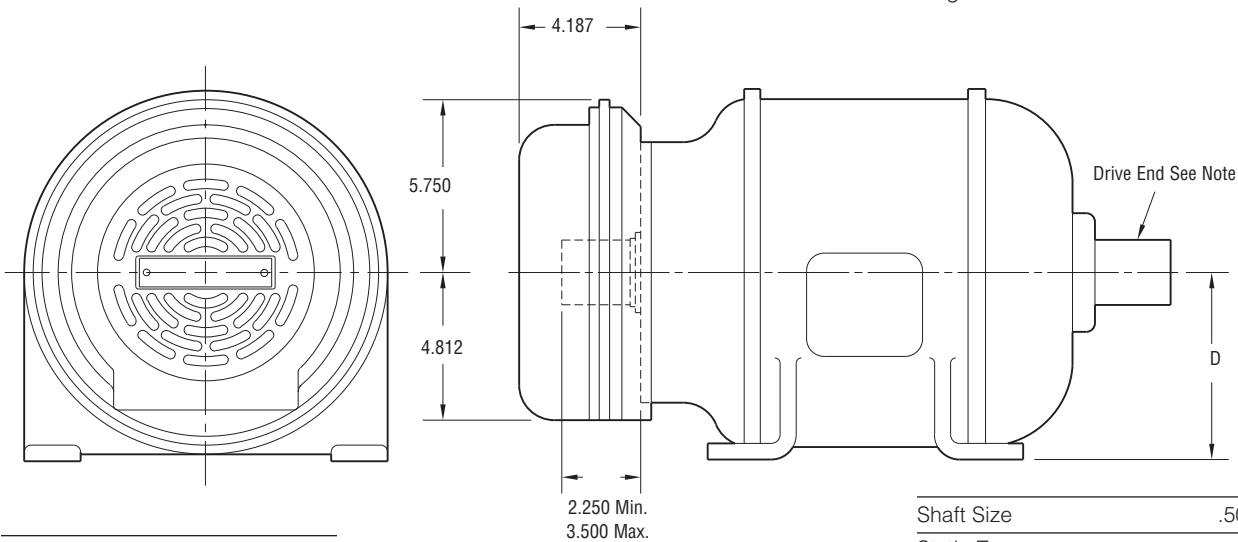

NEMA Frame Sizes	Dim. D
213C & 215C or TC	5.250
254C & 256C or TC	6.250

Shaft Size	.500 – 1.500
Static Torque	80 lb. ft.
Maximum Speed	4,000 rpm
Standard Voltage	D.C. 90

All dimensions are nominal unless otherwise noted.

Information on inertia and weights begins on page 239. Coil data is on pages 250 and 251.



MB-825 Flange Mounted

Drawing I-25576

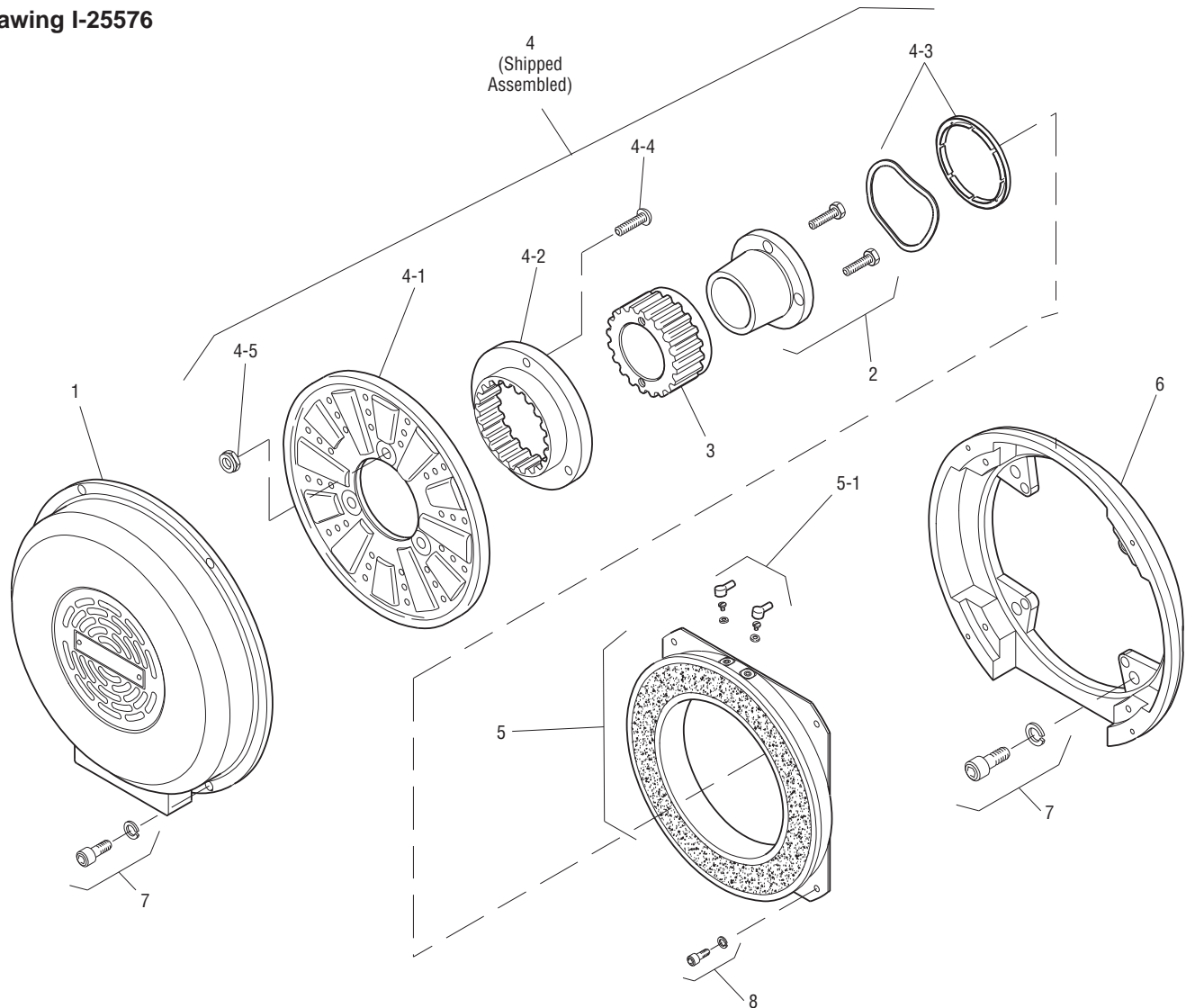

Item	Description	Part Number	Qty.
1	Cover	5351-288-001	1
2	Bushing*		1
	1/2" to 1-1/2" Bore	180-0002 to 180-0018	
3	Armature Hub	540-0057	1
4	Armature Assembly	5321-111-001	1
4-1	Armature	5321-111-022	1
4-2	Splined Adapter	104-0008	1
4-3	Autogap Accessory	5321-101-006	1
4-4	Screw	797-0272	3
4-5	Locknut	661-0004	3
5	Magnet	5351-631-001	1
5-1	Terminal Accessory	5311-101-001	1
6	Adapter	5351-105-001	1
7	Mounting Accessory	5351-101-003	1
8	Mounting Accessory	5321-101-002	1

How to Order:

1. MB-825 Adapts to NEMA C Face, Double Shaft Motors, Frame Sizes 213 C, 215 C, 254 UC and 256 UC.
2. Specify Bore Size for Item 4. (Frame size determines bore).
3. See Controls Section.

Example:

MB-825 Motor Brake per I-25576 - 90 Volt, 7/8" Bore

These units meet the standards of UL508 and are listed under guide card #NMTR2, file #59164. These units are CSA certified under file #LR11543.

*See page 252 for specific part numbers.

Refer to Service Manual P-208.

Motor Brake

Normal Duty

MB-1000 Flange Mounted

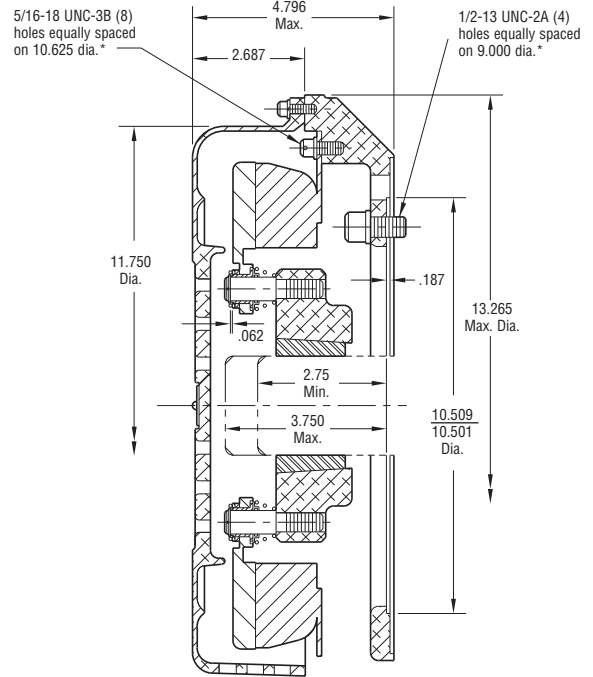
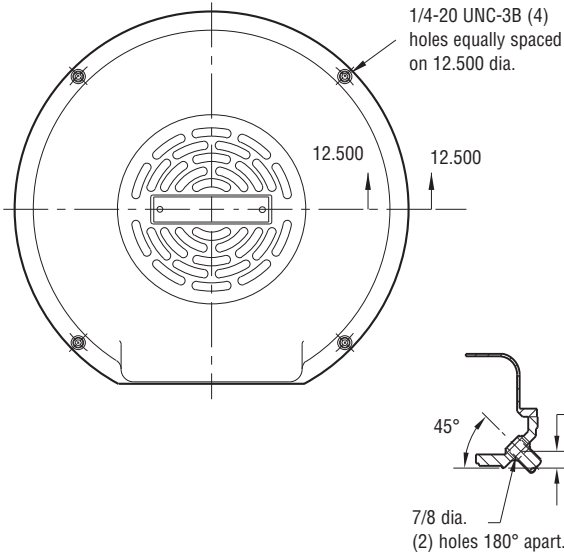

Installation

* Mounting holes are within .006 of true position.

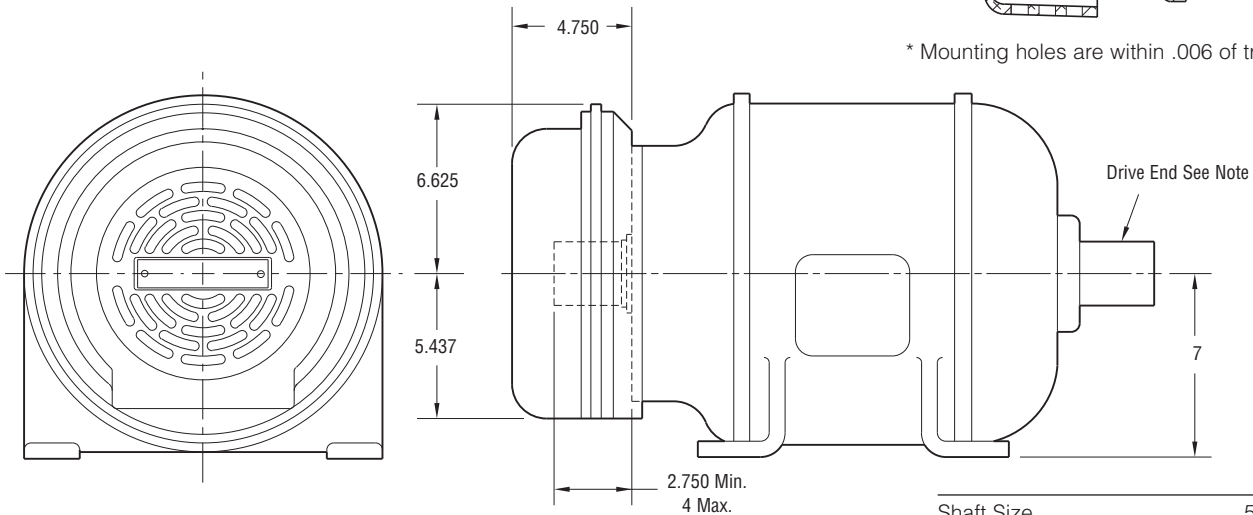

Shaft Size	.500 – 2.500
Static Torque	160 lb. ft.
Maximum Speed	3,600 rpm
Standard Voltage	D.C. 90

All dimensions are nominal unless otherwise noted.

Information on inertia and weights begins on page 239. Coil data is on pages 250 and 251.



Drawing I-25591

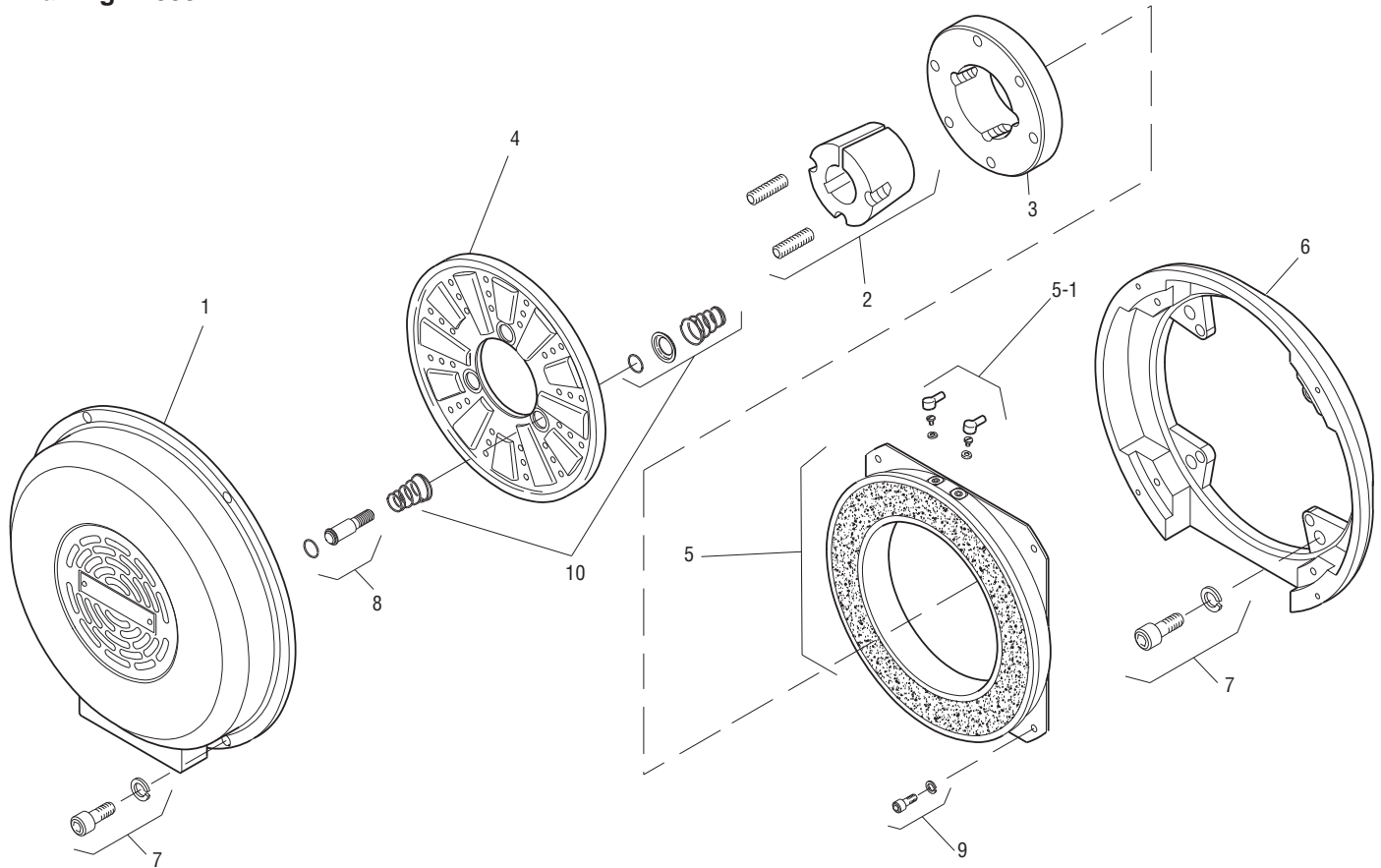

Item	Description	Part Number	Qty.
1	Cover	5352-288-001	1
2	Bushing*		1
	1/2" to 2-1/2" Bore	180-0185 to 180-0217	
3	Armature Hub	540-0313	1
4	Armature	5302-111-013	1
5	Magnet - 90 Volt	5352-631-001	1
5-1	Terminal Accessory	5311-101-001	1
6	Adapter	5352-105-001	1
7	Mounting Accessory	5351-101-003	1
8	Drive Pin and Retainer	5301-101-001	3
9	Mounting Accessory	5321-101-002	2
10	Spring Accessory	5301-101-014	3

How to Order:

1. MB-1000 Adapts to NEMA C Face, Double Shaft Motors, Frame Sizes 284 UC and 286 UC.
2. Specify Bore Size for Item 2. (Frame size determines bore).
3. See Controls Section.

Example:

MB-1000 Motor Brake per I-25591 - 90 Volt, 1-3/8" Bore

These units meet the standards of UL508 and are listed under guide card #NMTR2, file #59164. These units are CSA certified under file #LR11543.

*See page 252 for specific part numbers.

Refer to Service Manual P-208.

Motor Brake

Heavy Duty

MB-1000 Flange Mounted

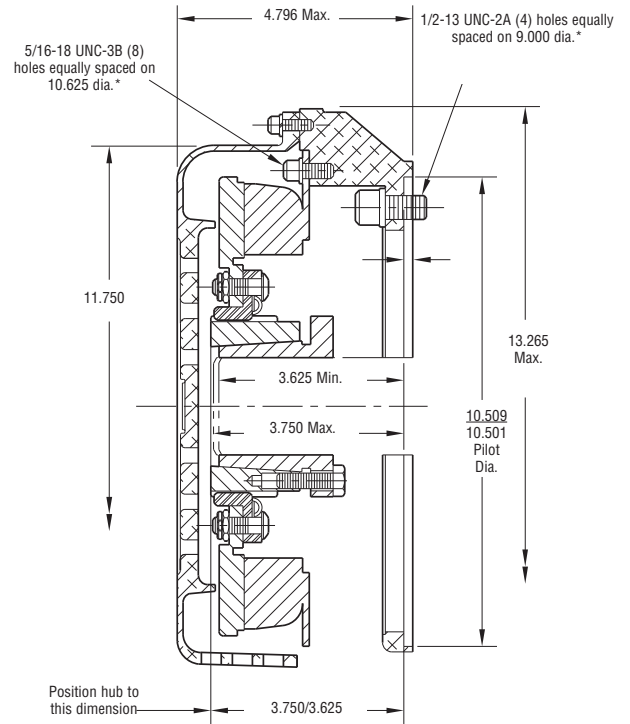
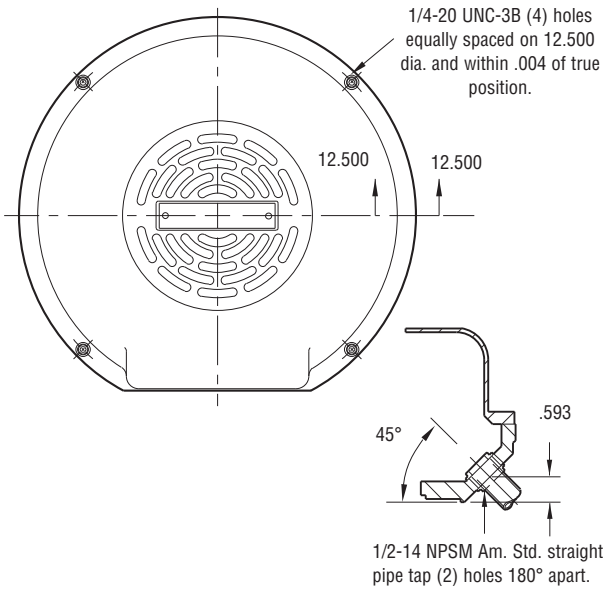

Installation

* Mounting holes are within .006 of true position.

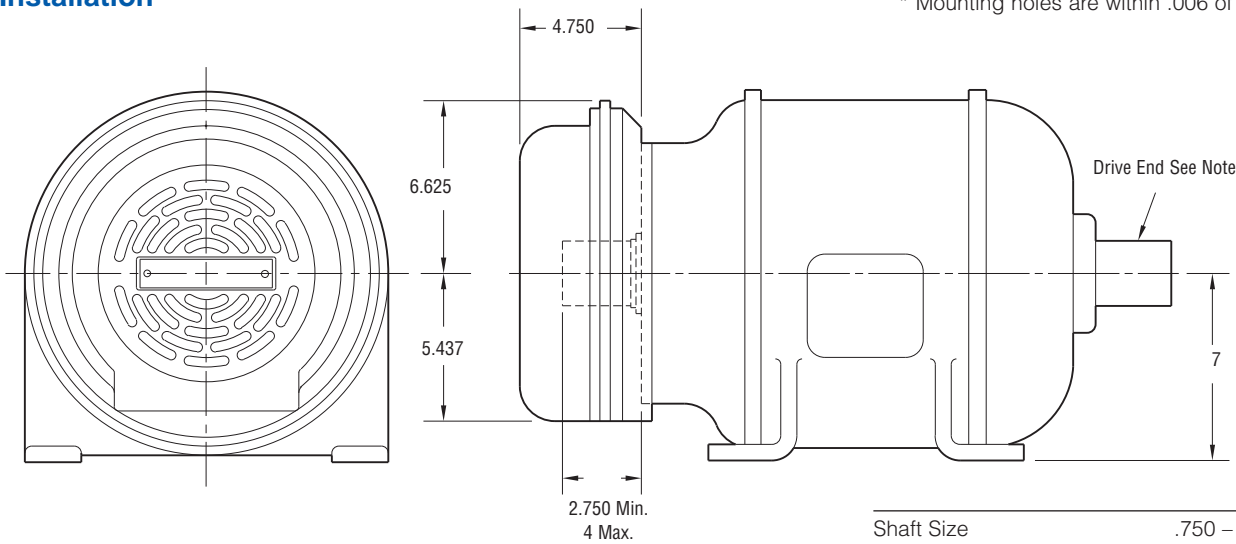

Shaft Size	.750 – 2.687
Static Torque	160 lb. ft.
Maximum Speed	3,600 rpm
Standard Voltage	D.C. 90

All dimensions are nominal unless otherwise noted.

Information on inertia and weights begins on page 239. Coil data is on pages 250 and 251.



Drawing I-25595

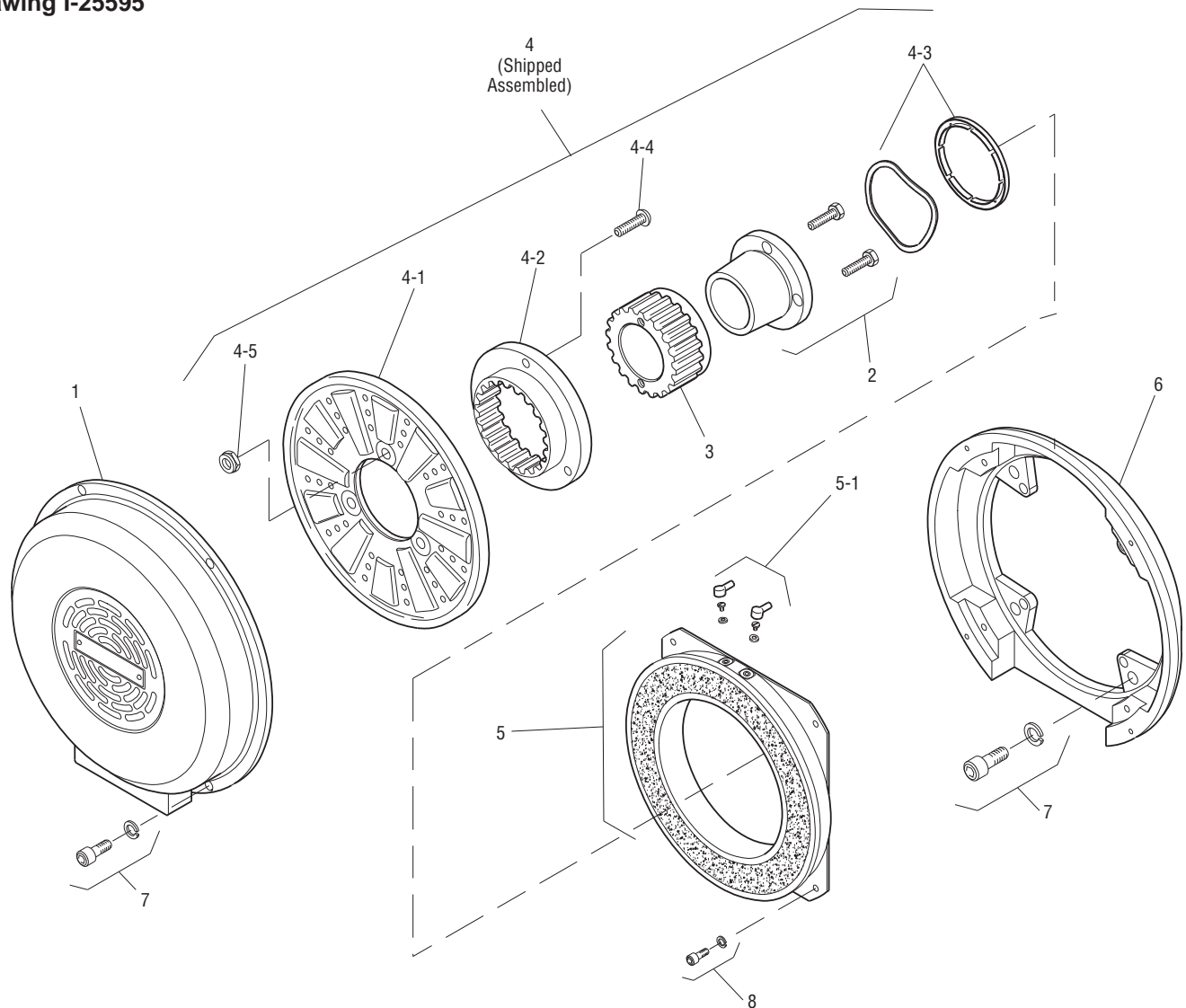

Item	Description	Part Number	Qty.
1	Cover	5352-288-001	1
2	Bushing*	180-0026 to 180-0057	1
3	Armature Hub	540-0062	1
4	Armature Assembly	5322-111-002	1
4-1	Armature	5322-111-036	1
4-2	Splined Adapter	104-0009	1
4-3	Autogap Accessory	5322-101-004	1
4-4	Screw	797-0272	3
4-5	Locknut	661-0004	3
5	Magnet	5352-631-001	1
5-1	Terminal Accessory	5311-101-001	1
6	Adapter	5352-105-001	1
7	Mounting Accessory	5351-101-003	2
8	Mounting Accessory	5321-101-002	1

How to Order:

1. MB-1000 Adapts to NEMA C Face, Double Shaft Motors, Frame Sizes 284 UC and 286 UC.
2. Specify Bore Size for Item 4. (Frame size determines bore).
3. See Controls Section.

Example:

MB-1000 Motor Brake per I-25595 - 90 Volt, 1-3/8" Bore
 These units meet the standards of UL508 and are listed under guide card #NMTR2, file #59164. These units are CSA certified under file #LR11543.

*See page 252 for specific part numbers.

Refer to Service Manual P-208.

Motor Brake

Normal Duty

MB-1225 Flange Mounted

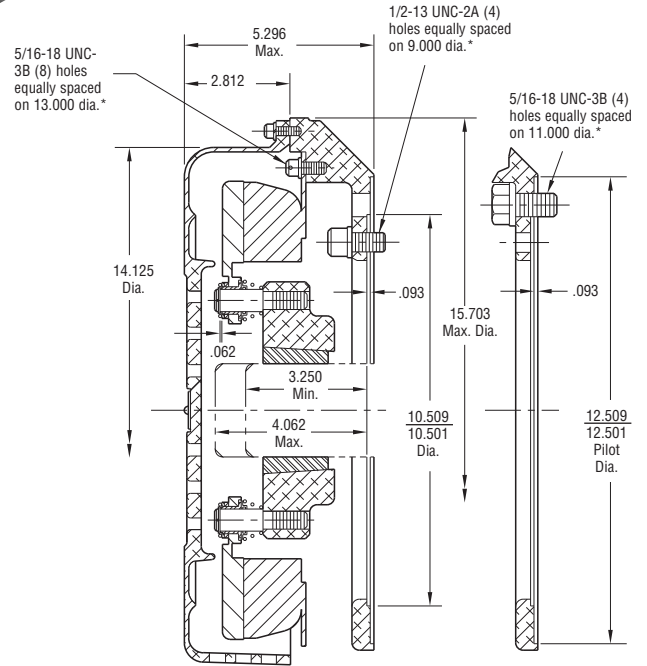
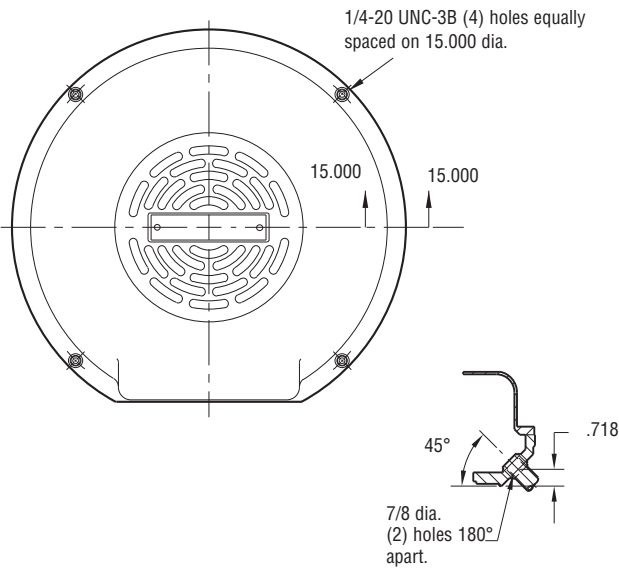

Installation

* Mounting holes are within .006 of true position.

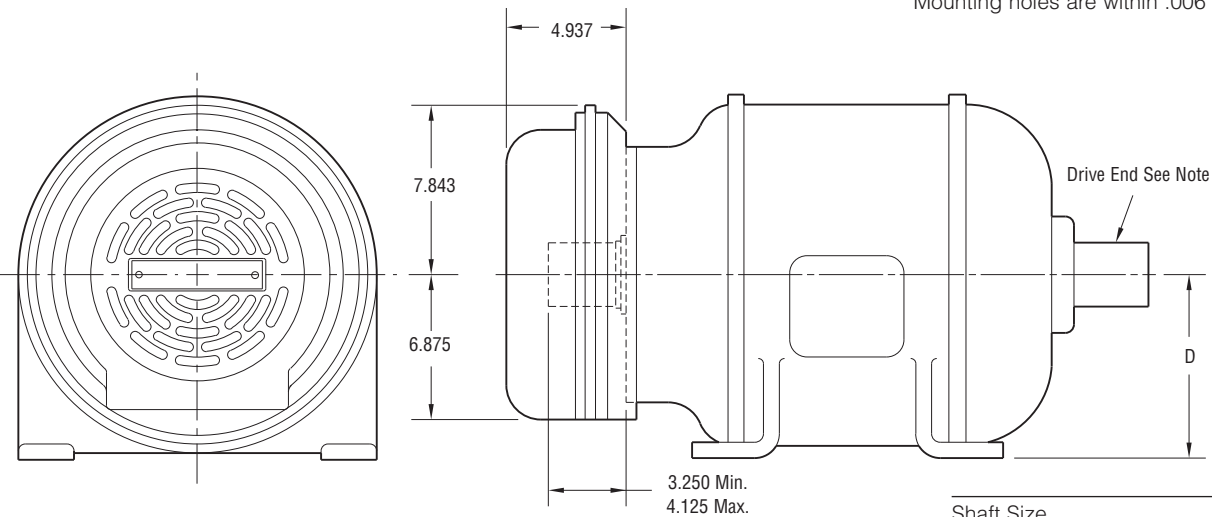

NEMA Frame Sizes	Dim. D
284C & 286C or TC	7
324C & 326C or TC	8
364C & 365C or TC	9

Shaft Size	.500 – 2.500
Static Torque	260 lb. ft.
Maximum Speed	3,000 rpm
Standard Voltage	D.C. 90

All dimensions are nominal unless otherwise noted.

Information on inertia and weights begins on page 239. Coil data is on pages 250 and 251.



Drawing I-25614

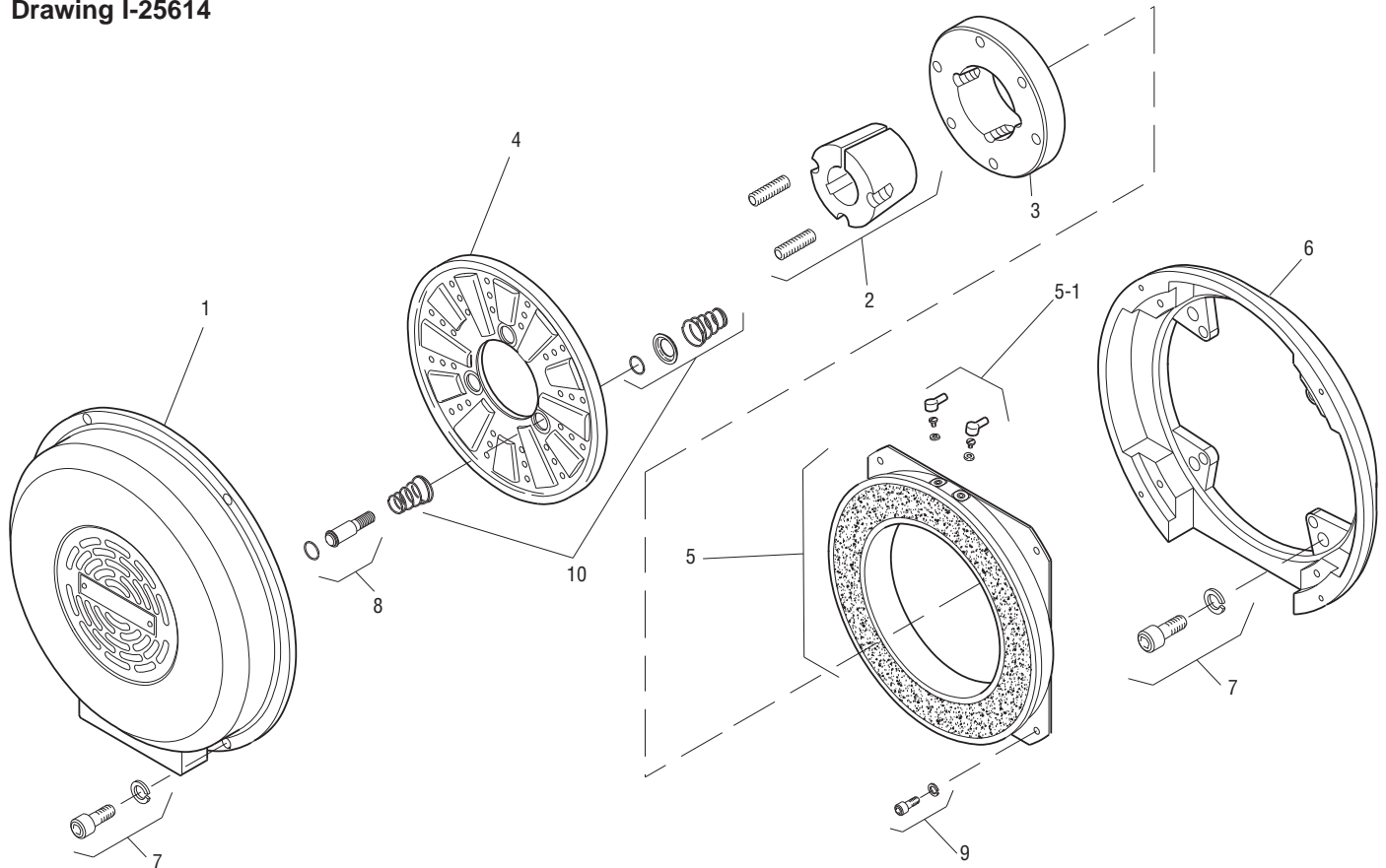

Item	Description	Part Number	Qty.
1	Cover	5353-288-001	1
2	Bushing*		1
	1/2" to 2-1/2" Bore	180-0185 to 180-0217	
3	Armature Hub	540-0014	1
4	Armature	5303-111-009	1
5	Magnet - 90 Volt	5353-631-001	1
5-1	Terminal Accessory	5311-101-001	1
6	Adapter	5353-105-002	1
7	Mounting Accessory	5351-101-003	1
8	Drive Pin and Retainer	5301-101-001	4
9	Mounting Accessory	5321-101-002	2
10	Spring Accessory	5303-101-006	4

How to Order:

1. MB-1225 Adapts to NEMA C Face, Double Shaft Motors, Frame Sizes 284, 284 UC, 324 UC, 326 UC, 364 UC and 365 UC.
2. Specify Bore Size for Item 2. (Frame size determines bore).
3. See Controls Section.

Example:

MB-1225 Motor Brake per I-25614 - 90 Volt, 1-5/8" Bore
 These units meet the standards of UL508 and are listed under guide card #NMTR2, file #59164. These units are CSA certified under file #LR11543.

*See page 252 for specific part numbers.

Refer to Service Manual P-208.

Motor Brake

Heavy Duty

MB-1225 Flange Mounted

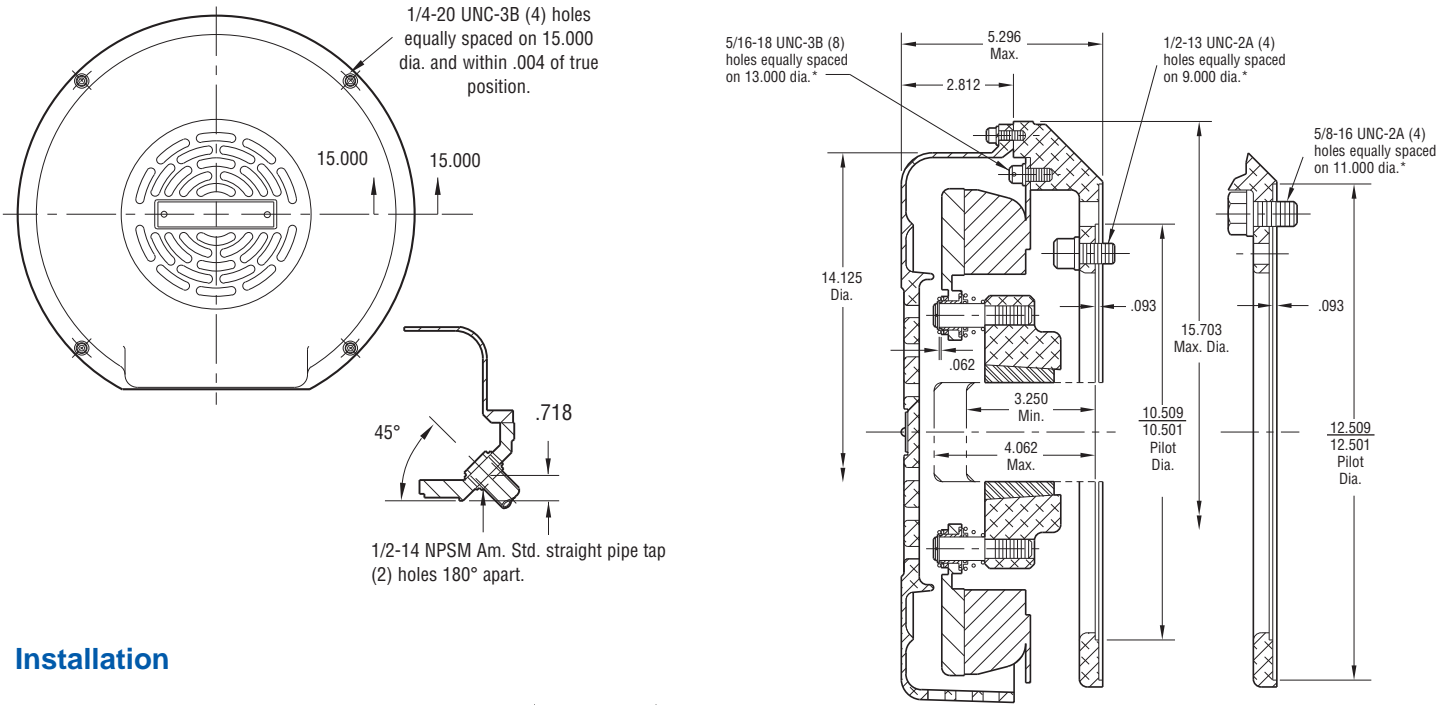

Installation

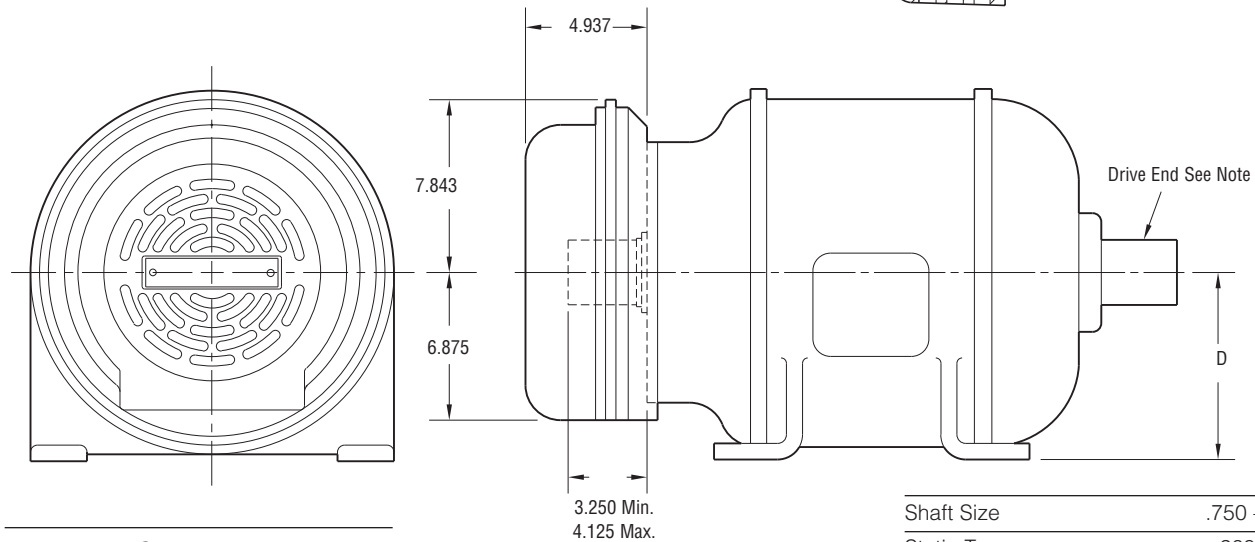

NEMA Frame Sizes	Dim. D
284C & 286C or TC	7
324C & 326C or TC	8
364C & 365C or TC	9

Shaft Size	.750 – 2.687
Static Torque	260 lb. ft.
Maximum Speed	3,000 rpm
Standard Voltage	D.C. 90

All dimensions are nominal unless otherwise noted.

Information on inertia and weights begins on page 239. Coil data is on pages 250 and 251.



Drawing I-25618

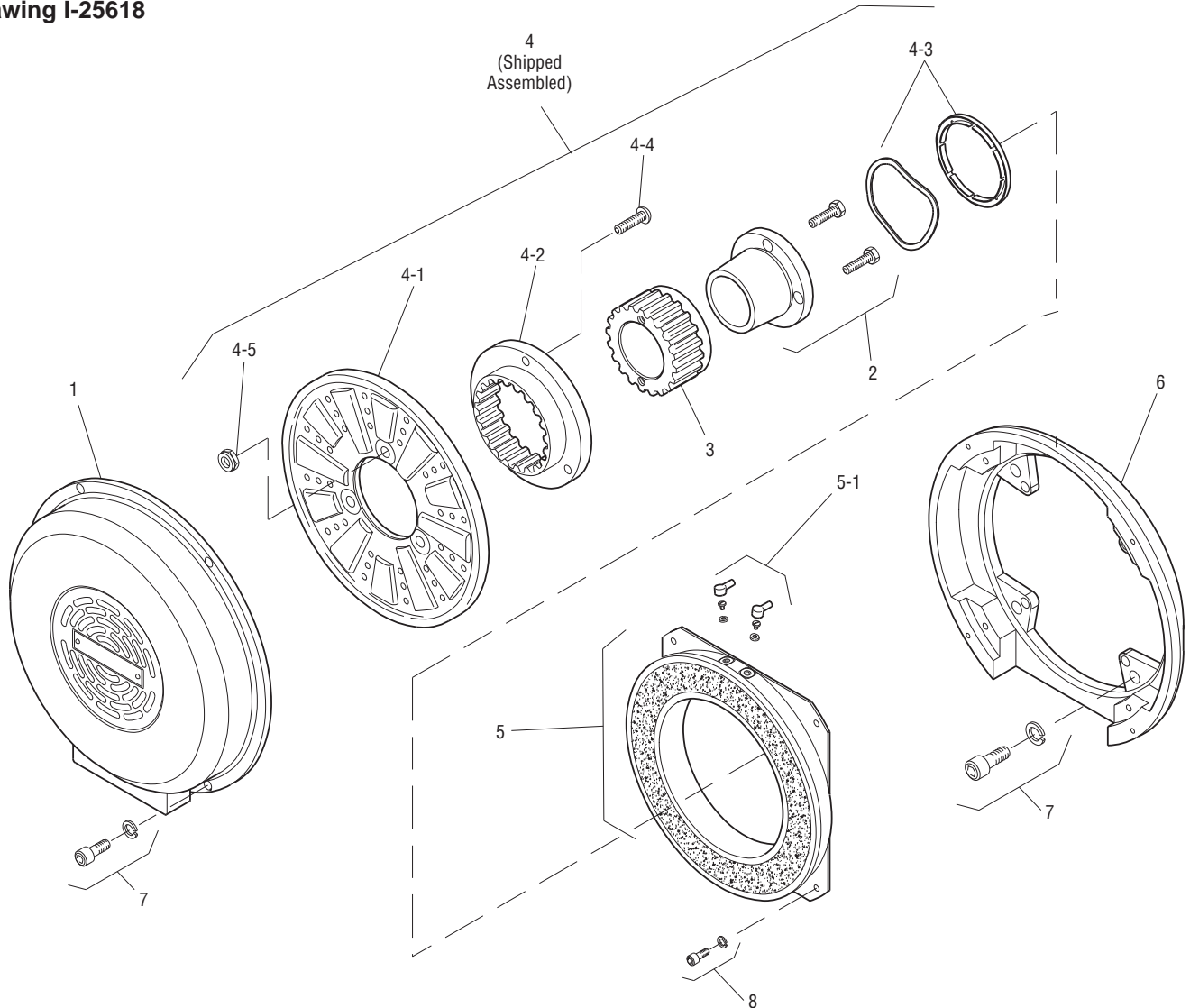

Item	Description	Part Number	Qty.
1	Cover	5353-288-001	1
2	Bushing*		1
	3/4" to 2-11/16" Bore	180-0026 to 180-0057	
3	Armature Hub	540-0064	1
4	Armature Assembly	5323-111-001	1
4-1	Armature	5323-111-034	1
4-2	Splined Adapter	104-0010	1
4-3	Autogap Accessory	5323-101-002	1
4-4	Screw	797-0281	4
4-5	Locknut	661-0005	4
5	Magnet	5353-631-001	1
5-1	Terminal Accessory	5311-101-001	1
6	Adapter	5353-105-002	1
7	Mounting Accessory	5351-101-003	2
8	Mounting Accessory	5321-101-002	1

How to Order:

1. MB-1225 Adapts to NEMA C Face, Double Shaft Motors, Frame Sizes 284, 284 UC, 324 UC, 326 UC, 364 UC and 365 UC.
2. Specify Bore Size for Item 2. (Frame size determines bore).
3. See Controls Section.

Example:

MB-1225 Motor Brake per I-25618 - 90 Volt, 1-5/8" Bore
 These units meet the standards of UL508 and are listed under guide card #NMTR2, file #59164. These units are CSA certified under file #LR11543.

*See page 252 for specific part numbers.

Refer to Service Manual P-208.