

For Dynamic Stopping and Cycling Applications

Warner Electric's modular design brakes and clutch/brake units offer material handling system users a high performance alternative to spring-set brakes. These modular units provide long life, maintenance free operation, and consistent performance with minimal downtime.

These brakes are offered in power-off types for double shaft motors and for installation between C-face motor and reducer or other drive device. Powerful permanent magnets generate braking torque. The brakes release when voltage is applied to the coil, countering the force of the permanent magnets. No power is required to stop or hold a load. An optional integral conduit box provides simple wiring direct from the motor power leads.

- Designed for dynamic stopping operations
- Brake automatically engages when power is turned off
- High cycle rate capability
- Never needs adjustment – automatically compensates for wear
- Powerful permanent magnets provide braking force
- Choice of open or enclosed brakes
- Prepackaged, preburnished UM version

Three C-face Compatible Designs

The UM Series (UniModule Clutch/Brakes) are preassembled clutch/electrically released brake modules.

- The UM-1020-FBC brake/motor clutch combination is used for clutch/power-off brake applications. It mounts directly to C-face compatible components.
- The UM-2030-FBC brake/input clutch combination is used for clutch/power-off brake applications. It has shafts on both the input and output sides for base mounting.

The EUM Series (Enclosed Motor Brakes) are totally enclosed non-vented units that keep wear particles in and contaminants out.

- The EUM-FBB brake unit can be mounted between two C-face compatible components.
- The EUM-MBFB motor brake is mounted directly to the rear of a double-shafted motor.

The EM Series (Electro Module Brakes and Clutch/Brakes) are comprised of individual units that may bolt together to form various combinations:

- The EM-FBB brake module mounts between a C-face motor and a gear box or reducer.
- The EM-MBFB motor brake module is mounted to the rear of a double-shafted motor.
- The EM-FBC brake module is used in combination with a motor clutch or input clutch unit to make a clutch/electrically released brake or can be used alone as a brake only.

Brake Modules (FBB) – For mounting between a C-face motor and a gearbox or reducer



EM Series
Shaft mounted,
vented housing



EUM Series
Shaft mounted,
totally enclosed
non-vented housing

Use for brake alone applications.

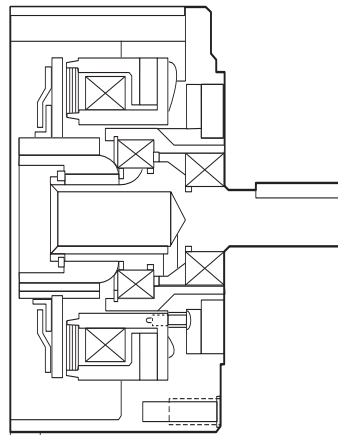

Features

- Single armature for brake alone applications
- Output shaft
- Permanent magnets
- UL listed and CSA certified

EM-FBB

Available in 4 sizes

EUM-FBB

Available in 4 sizes

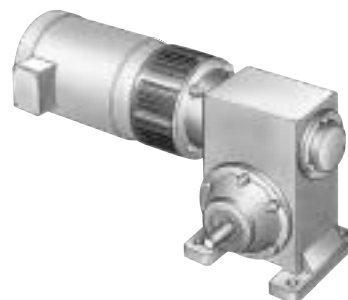

EM-FBB Electro Module
brake unit between a
motor and a reducer.

Permanent Magnet Modules

Electrically Released Brakes

C-face Compatible Brakes and Clutch/Brakes

Motor Brake Modules (MBFB) – For mounting directly to the rear of a double-shafted motor

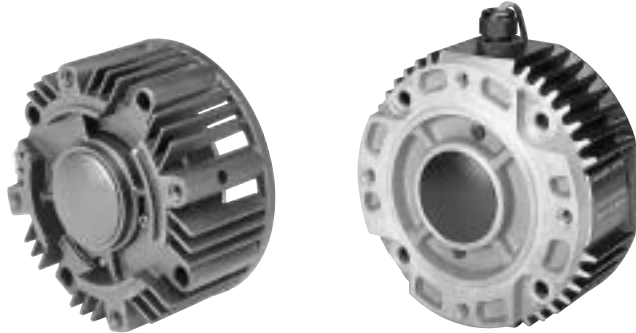

EM Series
vented housing

EUM Series
totally enclosed
non-vented
housing

Use as a motor brake on C-face type motors.

Clutch/Brake Modules (FBC) – Clutch/Fail-safe brake for mounting between a C-face motor and a gearbox or reducer

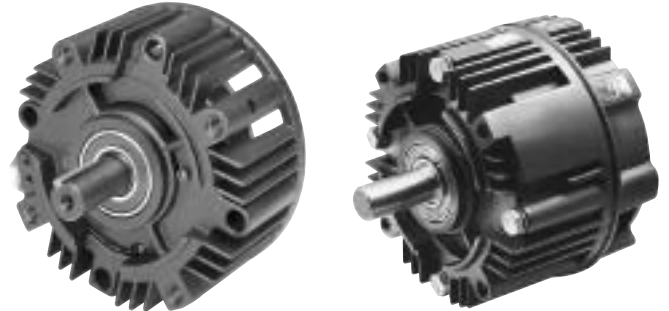

EM Series
Modular unit with
C/B capability

UM Series
Fully assembled C/B
combination package

Combine with a motor or input clutch for clutch/brake applications or use alone as a brake only.

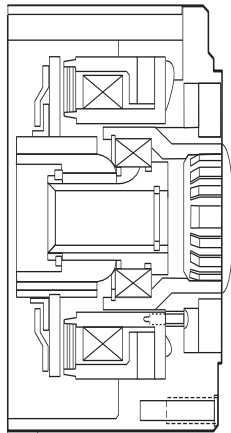

Features

- Single armature design
- Complete torque control
- Precision cast housing
- Ceramic type permanent magnets

EM-MBFB

Available in 4 sizes

EUM-MBFB

Available in 5 sizes

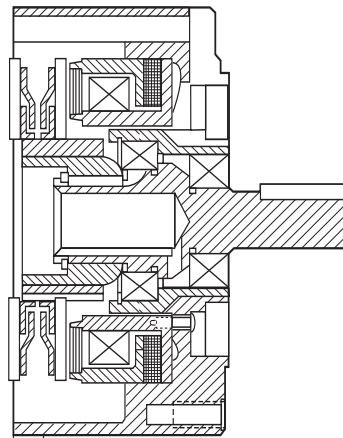

Features

- Dual armature for clutch/brake combination
- Output shaft
- Can be base mounted for use as a separate drive unit.

EM-FBC

Available in 3 sizes

UM-FBC

Available in 4 size combinations

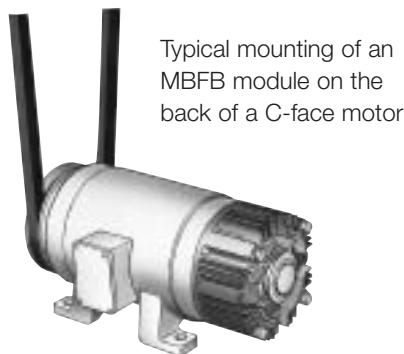

Typical mounting of an MBFB module on the back of a C-face motor

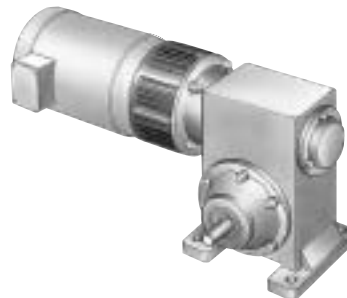

EM-FBC Electro Module brake unit combined with a motor clutch module

UM-FBC UniModule clutch/brake mounted on a base

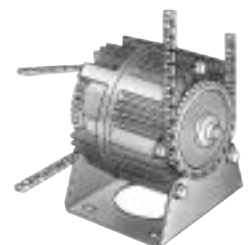

UniModule Clutch/Electrically Released Brake Combination

Fan cooled for long life and consistent performance.

NEMA C-face compatible design

Single conduit entrance

Heavy duty bearings maintain tight concentricity and running efficiency.

High torque, long life, asbestos-free friction material

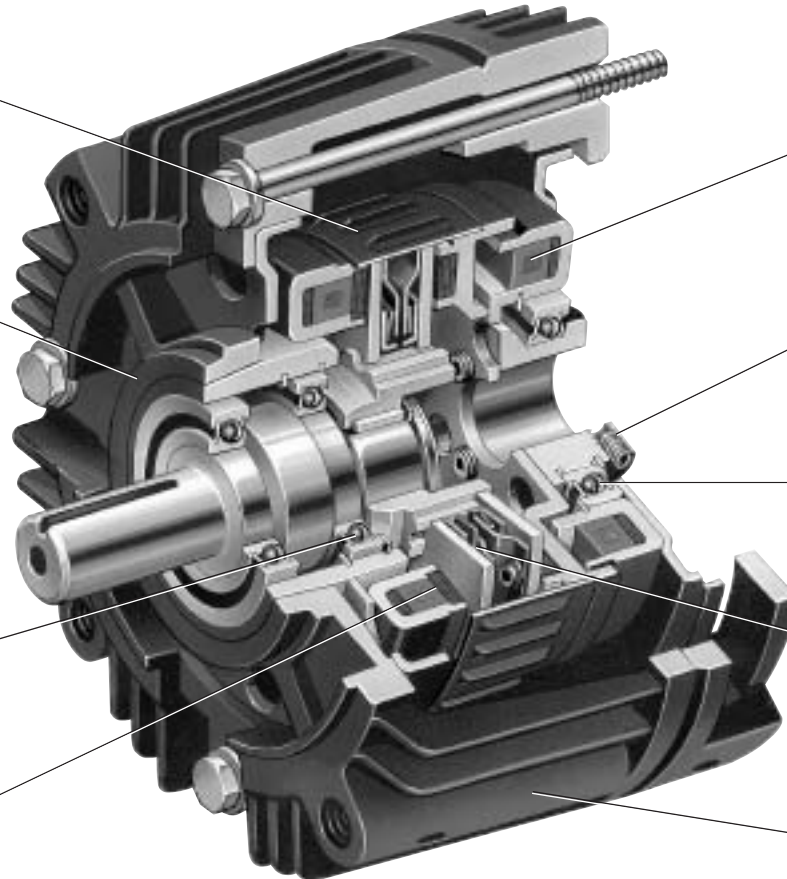

Completely sealed coils

Easy set screw access

Bearing mounted rotor.

Autogaps® automatically adjust for wear.

Finned design for maximum heat dissipation.

Warner Electric offers the convenience of pre-assembled UniModule clutch/electrically released brake packages. Assembly, alignment, and pre-burnishing have been done at the factory. Bolt it on, wire it up, and your clutch/electrically released brake is ready to go. Available in both C-face and base mounted versions.

Warner Electric's unique design employs powerful permanent magnets for maximum torque when power is removed from the brake coil. A small amount of electrical power applied to the brake coil nullifies the permanent magnets and the brake releases. No springs to limit cycle rates. Never any adjustments. No

lubrication. These brakes are recommended for dynamic cycling operations only.

UniModule clutch/electrically released brake units may be mounted directly to NEMA C-face motors and reducers, or can be base mounted.

1. Select Configuration

a. NEMA C-face Mounting (1020 Configuration)

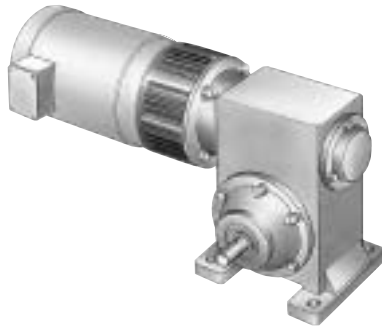

Verify the unit will be cycled frequently.

To select the correct UniModule package, determine the NEMA frame size of your motor and/or reducer, and choose the corresponding size UniModule from the Frame Size Selection chart. Verify torque ratings.

b. Base Mounting (2030 Configuration)



Verify the unit will be cycled frequently.

Select the correct size module from the Horsepower vs. Shaft Speed chart by determining the motor horsepower and RPM at the module location. The correct size UniModule is shown at the intersection of the HP and operating speed. For additional sizing information, refer to the technical sizing procedure (step 2).

2. Determine Technical Requirements

Technical considerations for sizing and selection are torque and heat dissipation. Each merits careful consideration, especially heat dissipation as over time, use in excessive temperature environments will have an adverse effect on bearing life and coil wire insulation integrity.

Compare the calculated torque requirement with the average dynamic torque ratings. Select a unit with adequate torque. If the unit selected on torque is different than the unit selected based on heat, select the larger size unit.

Horsepower vs. Shaft Speed

HP	SHAFT SPEED AT CLUTCH (IN RPM)																		
	100	200	300	400	500	600	700	800	900	1000	1100	1200	1500	1800	2000	2400	3000	3600	
1/4																			
1/2																			
3/4																			
1																			
1-1/2																			
2																			
3																			
5																			
7-1/2																			

Frame Size Selection and Technical Ratings Chart

NEMA Frame Size	UniModule Size	Static Torque Brake lb.ft.	Static Torque Clutch lb.	Max. RPM	Voltage DC
56C/48Y	UM-50* UM-100**	10.5 21	16 30	3600	24 or 90
182C/143TC 184C/145TC	UM-180	21	30	3600	24 or 90
213C/182TC 215C/184TC	UM-210	56	95	3600	24 or 90
213TC/215TC	UM-215	56	95	3600	24 or 90

*For 56C/48Y C-frame motors 3/4 HP and smaller, the UM-100 size may be used where extended life is desirable.

**The UM-100 size is recommended for motors 1 HP and larger.

a. Heat Dissipation Sizing

Friction surfaces slip during the initial period of engagement and, as a result, heat is generated. The clutch/brake selected must have a heat dissipation rating greater than the heat generated by the application. Therefore, in high inertia or high cycle rate applications, it is necessary to check the heat dissipation carefully. Inertia, speed and cycle rate are the required parameters.

Heat dissipation requirement is calculated as follows:

$$E = 1.7 \times WR^2 \times (N/100)^2 \times F$$

where:

$$E = \text{Heat (lb. ft./min.)}$$

WR^2 = Total reflected inertia at the clutch/brake shaft. Include the clutch/brake output inertia. (lb.ft.²)

N = Speed in revolutions per minute. (RPM)

F = Cycle rate in cycles per minute (CPM)

Compare the calculated heat generated in the application to the unit ratings using the heat dissipation curves. Select the appropriate unit that has adequate heat dissipation ability.

Heat Dissipation Curves

Size 50

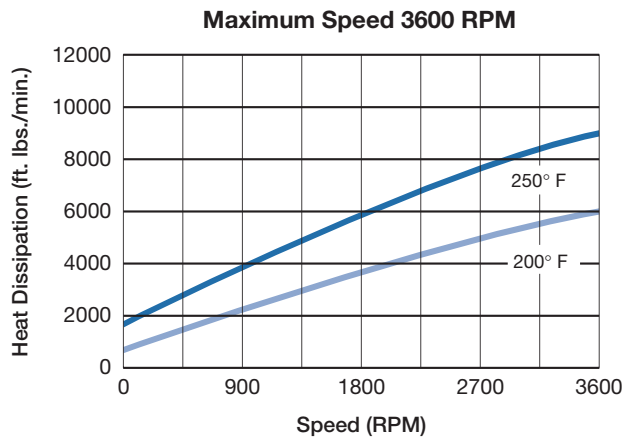

Size 100/180

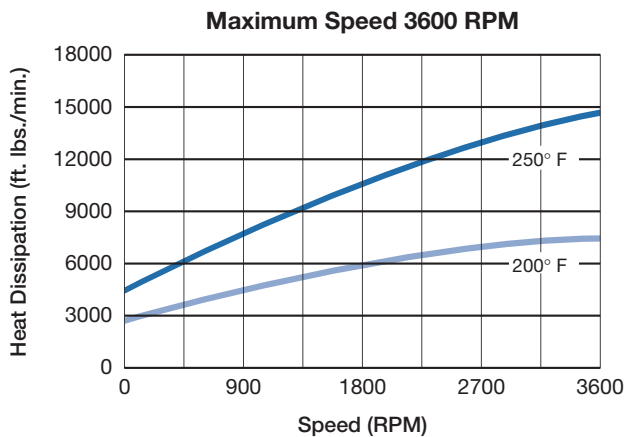

Size 210/215

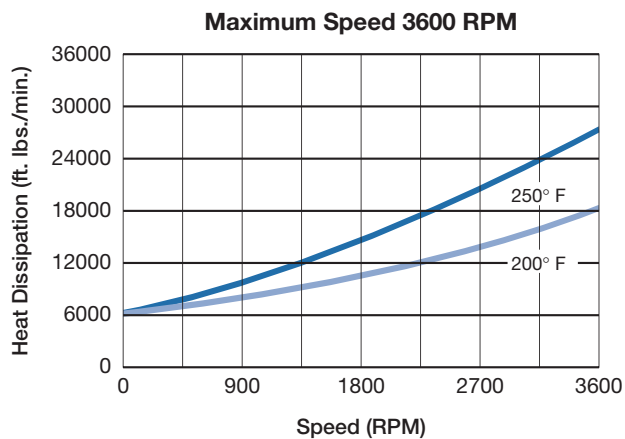

b. Torque Sizing

For most applications, the correct size clutch/brake can be selected from the Horsepower vs. Shaft Speed chart on page 117. Determine the motor horsepower and the RPM at the clutch/brake. The correct size unit is shown at the intersection of horsepower and shaft speed.

If the static torque requirements are known, refer to the technical ratings chart to select a unit.

For some applications, the torque requirement is determined by the time allowed to accelerate and decelerate the load. (This time is generally specified in milliseconds.) For these applications, it is necessary to determine the torque requirement based on load inertia and the time allowed for engagement.

The torque requirements are calculated as follows:

$$T = (WR^2 \times N) / (308 \times t)$$

where:

T = Average Dynamic Torque (lb. ft.)

WR^2 = Total reflected inertia at the clutch/brake shaft. Include the clutch/brake output inertia. (lb. ft.²)

N = Speed in revolutions per minute. (RPM)

t = Time allowed for the engagement (sec)

C-face Electrically Released Brake Dynamic Torque Curves

Size 50

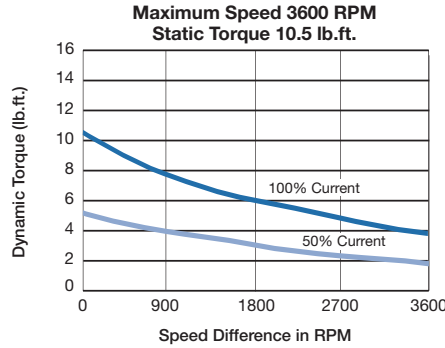

C-face Clutch Dynamic Torque Curves

Size 50

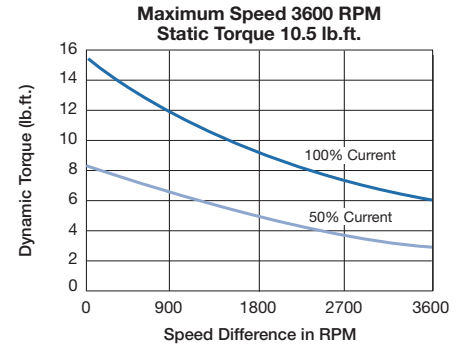

Size 100/180

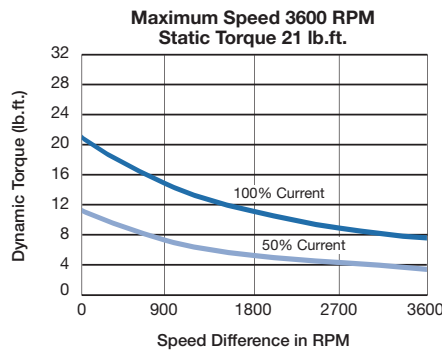

Size 100/180

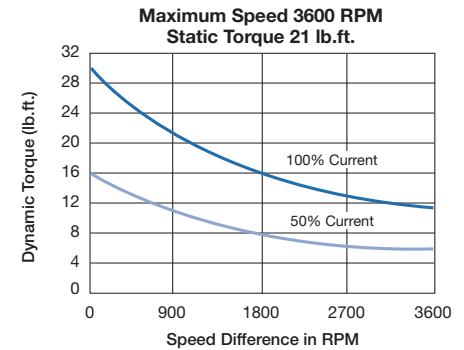

Size 210/215

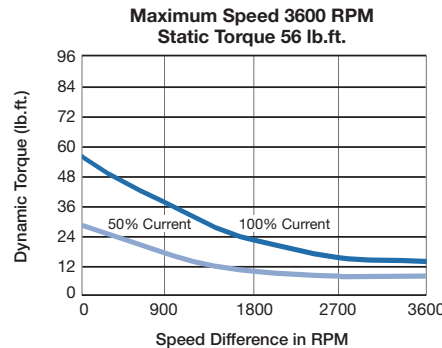

Size 210/215

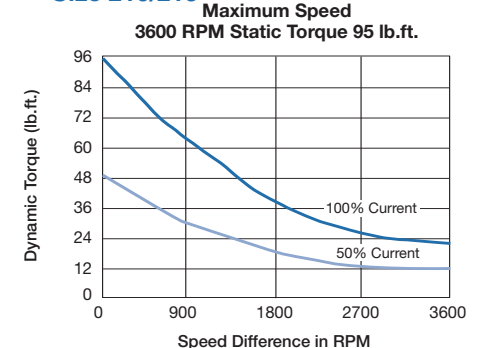

Specifications (Max. Speed 3600 RPM)

Size	Voltage DC	Nominal Weight (lbs.)		Armature		Component Inertia-WR ² (lb. ft. ²)					NEMA Frame Size
		1020	2030	(both)	Hub	1020		2030			
						Shaft	Rotor w/Fan and Hub	Output Shaft	Input Shaft	Rotor w/Fan and Hub	
50	24 90	12	15	.018	.001	.001	.020	.001	.001	.020	56C/48Y
100	24 90	16	19	.046	.002	.002	.046	.002	.002	.046	56C/48Y
180	24 90	16	19	.046	.002	.002	.046	.002	.002	.046	182C/143TC 184C/145TC
210	24 90	36	47	.162	.016	.014	.190	.016	.015	.183	213C/182TC 215C/184TC
215	24 90	37	48	.162	.016	.016	.190	.017	.016	.183	213TC/215TC

3. Select Options

Warner Electric Enclosed UniModules can be fitted with several accessories to extend their capacity and ease of mounting.

4. Select Control

All electrically released modules require a control with a potentiometer that will vary brake channel output. UM-FBC units require either a CBC-300 or a CBC 500/550 control.

UM Combination	UM Model No.	Voltage DC	Part No.
Motor Clutch/ ER Brake	UM-50-1020FBC	24	5370-273-037
	UM-50-1020FBC	90	5370-273-036
	UM-100-1020FBC	24	5370-273-153
	UM-100-1020FBC	90	5370-273-125
	UM-180-1020FBC	24	5370-273-047
	UM-180-1020FBC	90	5370-273-046
	UM-210-1020FBC	24	5371-273-013
	UM-210-1020FBC	90	5371-273-012
	UM-215-1020FBC	24	5371-273-099
	UM-215-1020FBC	90	5371-273-079
Input Clutch/ ER Brake	UM-50-2030FBC	24	5370-273-042
	UM-50-2030FBC	90	5370-273-041
	UM-100-2030FBC	24	5370-273-154
	UM-100-2030FBC	90	5370-273-155
	UM-180-2030FBC	24	5370-273-052
	UM-180-2030FBC	90	5370-273-051
	UM-210-2030FBC	24	5371-273-018
	UM-210-2030FBC	90	5371-273-017
	UM-215-2030FBC	24	5371-273-100
	UM-215-2030FBC	90	5371-273-101

Accessories

Description	UM Size	Part No.
Conduit Box	UM series All sizes	5370-101-042
Base Mount Kit for 2030 FBC	50/100	5370-101-036
	180	5370-101-037
	210/215	5371-101-039
Motor Mount Kit for 1020 FBC	50/100	5370-101-010
	180	5370-101-012
	210/215	5371-101-012

How to Order

1. Specify model number and voltage or the corresponding part number.
2. Specify conduit box, if desired. See the Controls Section.
3. Specify required control unit. See the Controls Section.

Ordering Example

UM-50-1020FBC, 90V or 5370-273-036; 5370-101-042 conduit box; CBC-300 control.

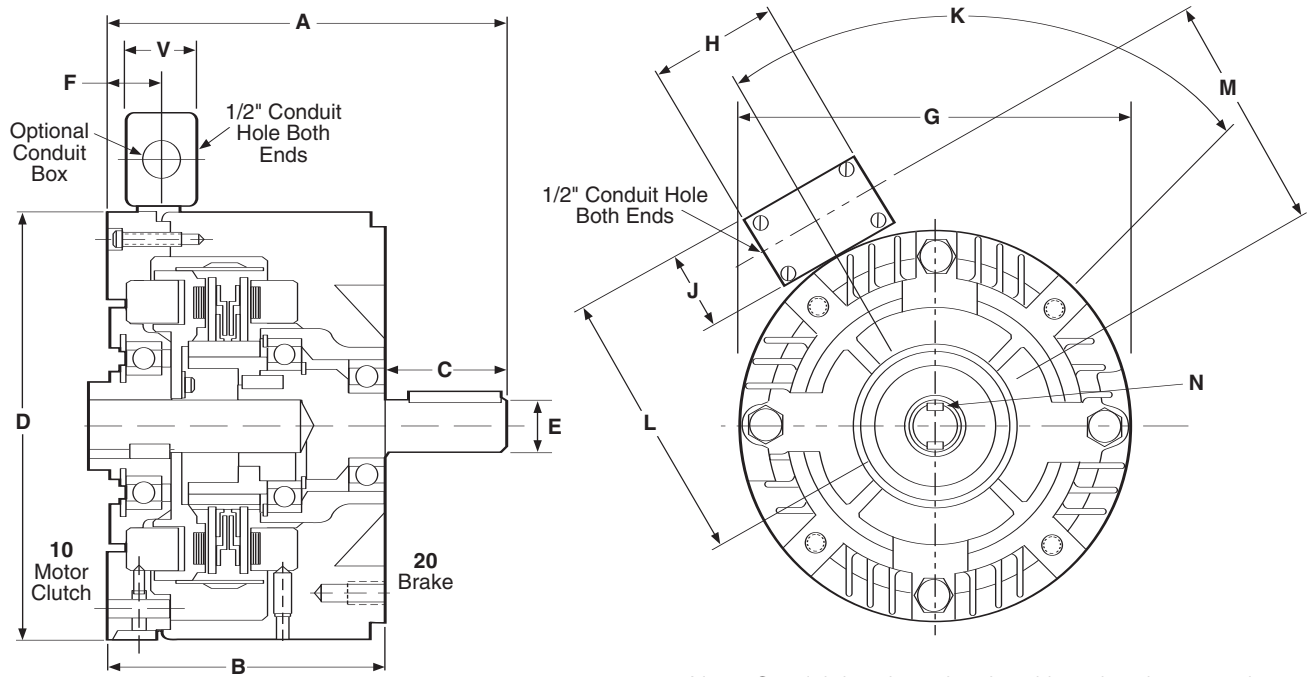

Note: Conduit box is optional and is ordered separately.

All dimensions are nominal, unless otherwise noted.

Size	A	B	C	D	E	F	G	H	J	K	L	M	N (Key)
50	7.281	5.375	1.813	6.750	.625	.938	6.688	3.250	2.188	75°	5.531	4.438	3/16 x 3/16 x 1-1/4
100	7.281	5.375	1.813	6.750	.625	.938	6.688	3.250	2.188	75°	5.531	4.438	3/16 x 3/16 x 1-1/4
180	7.359	5.375	1.891	6.750	.875	.938	6.688	3.250	2.188	75°	5.531	4.438	3/16 x 3/16 x 1-1/4
210	9.688	7.031	2.500	9.250	1.125	.625	9.688	3.250	2.188	70°	6.869	5.766	1/4 x 1/4 x 2
215	10.568	7.44	3.125	9.25	1.375	1.2	9.688	3.250	2.188	70°	6.869	5.766	5/16 x 5/16 x 2

Motor Mount (M)

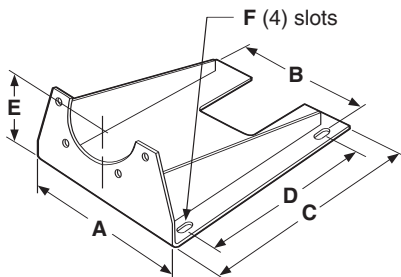

For use with 1020, 1040, 20, 20 FBB and 1020 FBC Combinations.

Size	A	B	C	D	E	F	Part No.
50/100	9.25	8.25	11.00	8.000	3.50	.797 x .406	5370-101-010
180	9.25	8.25	11.00	8.000	4.50	.797 x .406	5370-101-012
210/215	11.50	10.50	12.00	9.000	5.25	.750 x .406	5371-101-012

UM-2030 FBC Input Clutch/Electrically Released Brake

UM-2030 FBC-Input Clutch/Electrically Released Brake – Base Mounted

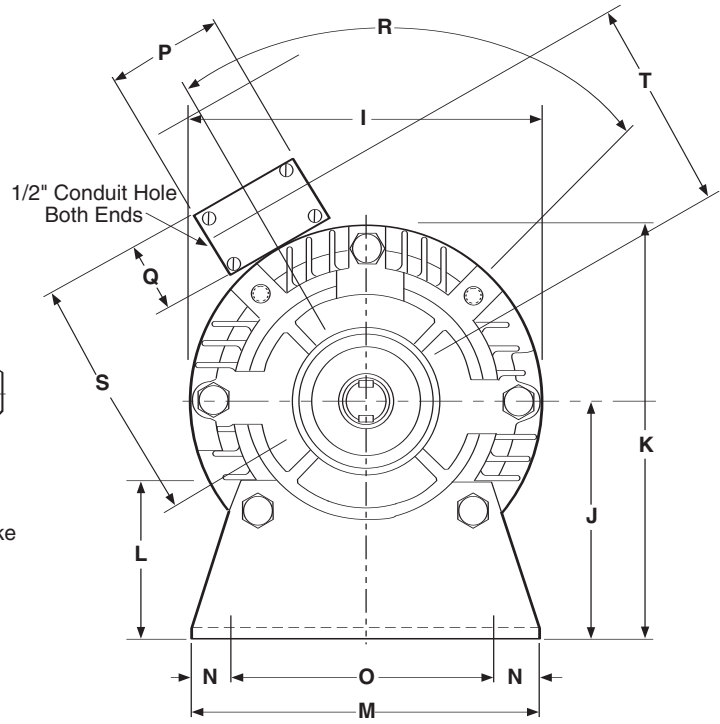
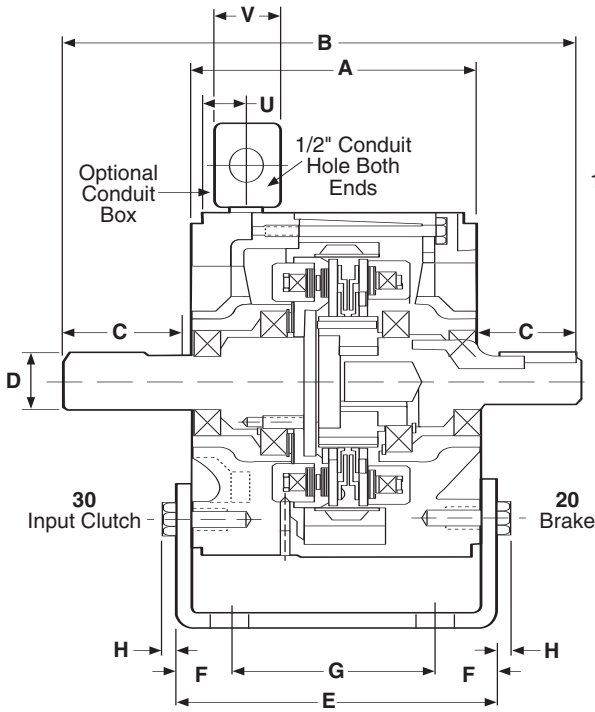

Note: Mounting base and conduit box are optional and are ordered separately.

All dimensions are nominal, unless otherwise noted.

Size	A	B	C Min.	D	E	F	G	H	I	J	K
50	6.250	10.047	1.813	.625	6.219	1.109	4.000	.344	6.688	3.500	6.844
180	6.250	10.188	1.891	.875	6.219	1.109	4.000	.344	6.688	4.500	7.844
210	8.516	13.766	2.500	1.125	8.938	1.469	6.000	.438	9.688	5.250	9.906

Size	L	M	N	O	P	Q	R	S	T	U	V
50	2.000	6.000	.500	5.000	3.250	2.188	75°	5.531	4.438	1.125	2.203
180	3.000	6.625	.813	5.000	3.250	2.188	75°	5.531	4.438	1.125	2.203
210	3.375	9.000	.625	7.750	3.250	2.188	70°	6.859	5.766	1.625	2.203

Base (B)

For use with 2030 FBC units.

Size	A	B	C	D	E	F	G	Part No.
50/100	6.000	5.000	6.219	4.000	.750 X .406	3.500	2.000	5370-101-036
180	6.625	5.000	6.219	4.000	.750 X .406	4.500	3.000	5370-101-037
210	9.000	7.750	8.938	6.000	.750 X .531	5.250	3.375	5371-101-019

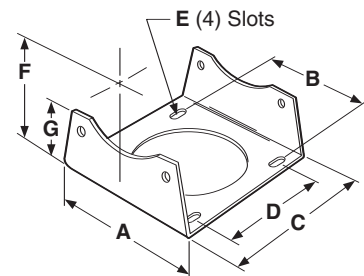

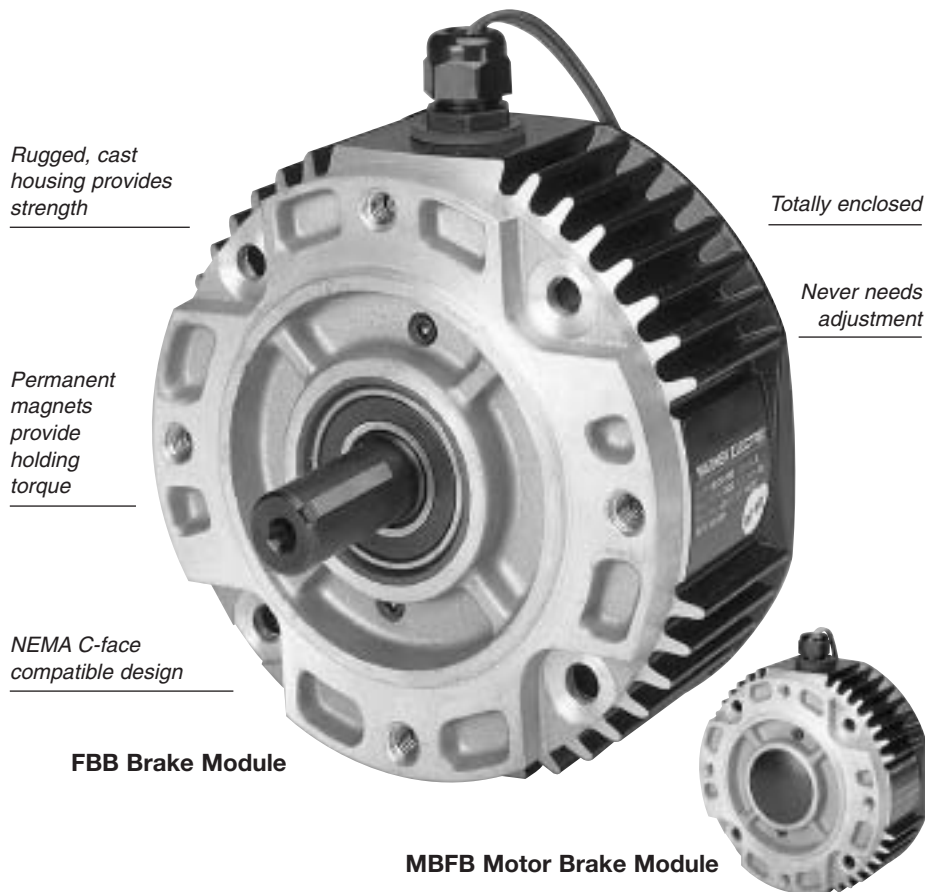

Available in Two Design Styles

EUM-FBB Brake Module

Use for brake alone applications. Mounts between a motor and gear box or reducer. Available in four sizes.

EUM-MBFB Motor Brake Module

Mounts to a double shafted C-face motor. Available in five sizes.

Warner Electric offers the convenience of pre-assembly in UniModule electrically released brake packages. Assembly, alignment, and preburnishing have been done at the factory. Bolt it on, wire it up, and your electrically released brake is ready to go. (Control and conduit box optional)

Care must be exercised to assure proper sizing and selection of electrically released brakes. Motor brakes are used for dynamic stopping and holding of loads when power is removed from the motor. Typical applications include conveyors, process equipment, and lifting devices.

Warner Electric brakes are designed for NEMA C-face motors which match the motor frame size and shaft diameter to the brake. To select a brake, determine the motor frame size and pick an MBFB for double shafted motors or an FBB for mounting between a motor and a gear reducer. Select the torque required for the

application. Higher torque brakes stop loads faster. Lower torque models provide softer stopping to prevent boxes on conveyors from tipping or skidding.

They are sized to provide nominal stopping of a motor in the event of power loss. If your application requires true "Fail safe" braking, the brake must be sized to meet or exceed peak motor torque and placed as close to the load shaft as possible. Peak motor torque can be determined by the formula:

$$\text{Peak Torque} = \frac{(\text{HP} \times 5250)}{\text{Motor Speed}}$$

EUM-FBB, EUM-MBFB Selection

Warner Electric Electrically Released Enclosed UniModules are available in two styles. The EUM-FBB Brake Module is used in brake only applications and mounts between a C-face motor and a gear box or reducer. The EUM-MBFB Motor Brake Module mounts to the back of a double shafted motor.

Note: Care must be exercised when selecting a brake to ensure it is sized properly for your application.

1. Select Configuration

a. FBB for NEMA C-face Mounting Between a Motor and Reducer

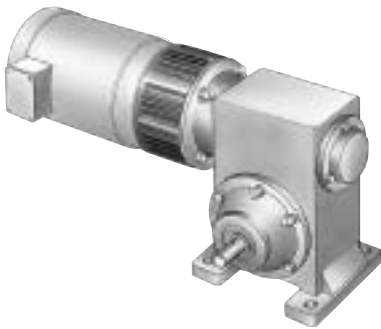

Verify that the brake will be cycled frequently.

Determine the NEMA C-face frame size of your motor and/or reducer, and choose the corresponding size Enclosed UniModule from the Frame Size Selection chart.

Size EUM-100 modules utilize a 5/8" diameter shaft to fit 56C/48Y motor frames with components of EUM-180 units for higher torque and heat dissipation capacity than the EUM-50.

EUM-FBB Frame Size Selection

NEMA Frame Size	EUM Size
56C/48Y	EUM-50* EUM-100**
182C/143TC 184C/145TC	EUM-180
213C/182TC 215C/184TC	EUM-210
213TC/215TC	EUM-215

*For 56C/48Y C-frame motors 3/4 HP and smaller, the EUM-100 size may be used where extended life is desirable.

**The EUM-100 size is recommended for motors 1 HP and larger.

b. MBFB for NEMA C-face Mounting on the Back of a Double Shafted Motor

Verify that the brake will be cycled frequently.

Determine the NEMA C-face frame size of your motor and/or reducer, and choose the corresponding size Enclosed UniModule MBFB from the Frame Size Selection chart, and verify that the motor shaft diameter and mounting bolt circle are the same for the brake and the motor.

Size EUM-100 modules utilize a 5/8" diameter shaft to fit 56C/48Y motor frames with components of EUM-180 units for higher torque and heat dissipation capacity than the EUM-50.

EUM-MBFB Frame Size Selection

NEMA Frame Size	EUM Brake Size	Bolt Hole Mounting Circle	Motor Shaft Dia.
56C/48Y	EUM-50*	5.875	0.625
	EUM-100**		
182C/143TC 184C/145TC	EUM-180	5.875	0.875
213C/182TC 215C/184TC	EUM-210-7/8 EUM-210	7.25 7.25	0.875 1.125

*For 56C/48Y C-frame motors 3/4 HP and smaller, the EUM-100 size may be used where extended life is desirable.

**The EUM-100 size is recommended for motors 1 HP and larger.

2. Determine Technical Requirements

Technical considerations for sizing and selection are torque and heat dissipation. Each merits careful consideration, especially heat dissipation as over time, use in excessive temperature environments will have an adverse effect on bearing life and coil wire insulation integrity.

Compare the calculated torque requirement with the average dynamic torque ratings. Select a unit with adequate torque. If the unit selected on torque is different than the unit selected based on heat, select the larger size unit.

Horsepower vs. Shaft Speed

HP	SHAFT SPEED AT CLUTCH (IN RPM)																	
	100	200	300	400	500	600	700	800	900	1000	1100	1200	1500	1800	2000	2400	3000	3600
1/4	Blue	Blue	Blue	Blue	Blue	Blue	Blue	Blue	Blue	Blue	Blue	Blue	Blue	Blue	Blue	Blue	Blue	Blue
1/2	Blue	Blue	Blue	Blue	Blue	Blue	Blue	Blue	Blue	Blue	Blue	Blue	Blue	Blue	Blue	Blue	Blue	Blue
3/4	Blue	Blue	Blue	Blue	Blue	Blue	Blue	Blue	Blue	Blue	Blue	Blue	Blue	Blue	Blue	Blue	Blue	Blue
1	Blue	Blue	Blue	Blue	Blue	Blue	Blue	Blue	Blue	Blue	Blue	Blue	Blue	Blue	Blue	Blue	Blue	Blue
1-1/2	Blue	Blue	Blue	Blue	Blue	Blue	Blue	Blue	Blue	Blue	Blue	Blue	Blue	Blue	Blue	Blue	Blue	Blue
2	Blue	Blue	Blue	Blue	Blue	Blue	Blue	Blue	Blue	Blue	Blue	Blue	Blue	Blue	Blue	Blue	Blue	Blue
3	Blue	Blue	Blue	Blue	Blue	Blue	Blue	Blue	Blue	Blue	Blue	Blue	Blue	Blue	Blue	Blue	Blue	Blue
5	Blue	Blue	Blue	Blue	Blue	Blue	Blue	Blue	Blue	Blue	Blue	Blue	Blue	Blue	Blue	Blue	Blue	Blue
7-1/2	Blue	Blue	Blue	Blue	Blue	Blue	Blue	Blue	Blue	Blue	Blue	Blue	Blue	Blue	Blue	Blue	Blue	Blue
10	Blue	Blue	Blue	Blue	Blue	Blue	Blue	Blue	Blue	Blue	Blue	Blue	Blue	Blue	Blue	Blue	Blue	Blue

a. Heat Dissipation Sizing

Friction surfaces slip during the initial period of engagement and, as a result, heat is generated. The clutch/brake selected must have a heat dissipation rating greater than the heat generated by the application. Therefore, in high inertia or high cycle rate applications, it is necessary to check the heat dissipation carefully. Inertia, speed and cycle rate are the required parameters.

Heat dissipation requirement is calculated as follows:

$$E = 1.7 \times WR^2 \times (N/100)^2 \times F$$

where:

$$E = \text{Heat (lb. ft./min.)}$$

WR^2 = Total reflected inertia at the clutch/brake shaft. Include the clutch/brake output inertia. (lb.ft.²)

N = Speed in revolutions per minute. (RPM)

F = Cycle rate in cycles per minute (CPM)

Compare the calculated heat generated in the application to the unit ratings using the heat dissipation curves. Select the appropriate unit that has adequate heat dissipation ability.

Heat Dissipation Curves

EUM 50

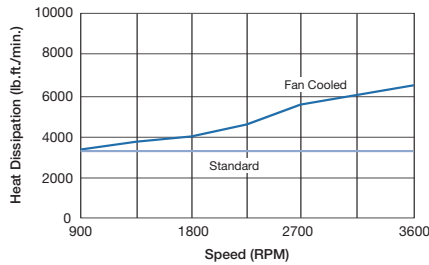

EUM 100/180

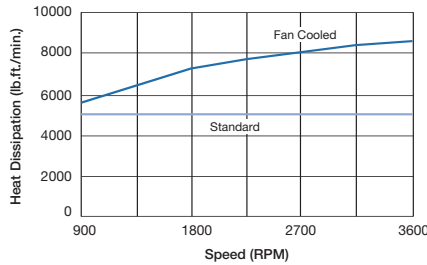

EUM 210/215 (fan not available for 215)

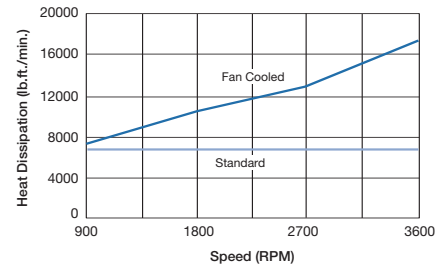

b. Torque Sizing

For most applications, the correct size clutch/brake can be selected from the Horsepower vs. Shaft Speed chart. Determine the motor horsepower and the RPM at the clutch/brake. The correct size unit is shown at the intersection of horsepower and shaft speed.

If the static torque requirements are known, refer to the technical ratings chart to select a unit.

For some applications, the torque requirement is determined by the time allowed to accelerate and decelerate the load. (This time is generally specified in milliseconds.) For these applications, it is necessary to determine the torque requirement based on load inertia and the time allowed for engagement.

The torque requirements are calculated as follows:

$$T = (WR^2 \times N) / (308 \times t)$$

where:

T = Average Dynamic Torque (lb. ft.)

WR^2 = Total reflected inertia at the clutch/brake shaft. Include the clutch/brake output inertia. (lb. ft.²)

N = Speed in revolutions per minute. (RPM)

t = Time allowed for the engagement (sec)

C-face Electrically Released Brakes Dynamic Torque Curves

Size 50

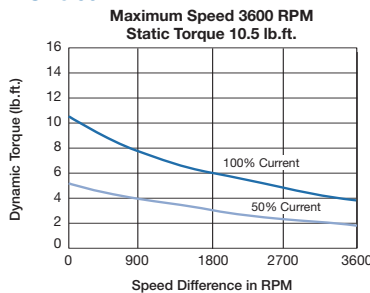

Size 100/180

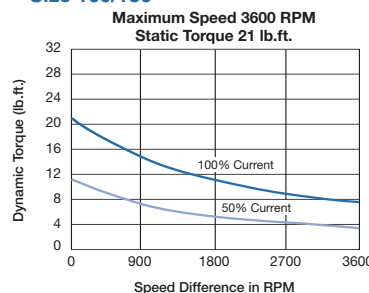

Size 210/215

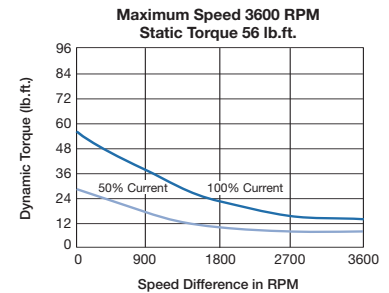

Preassembled, Totally Enclosed, Electrically Released Brake Units

Specifications

Size	Voltage DC	Static Torque (lb.ft.)	Max. Speed (RPM)	Total Weight (lbs.)	Armature (lb.ft. ²)	Component Inertia –WR ² (lb.ft. ²)				NEMA Frame Size
						FBB		MBFB		
						Hub	Shaft	Hub Spliced	Shaft Input	
50	90	6	3600	8.6	.009	.001	.0005	.001	.0003	56C/48Y
100	90	12	3600	10.5	.023	.002	.002	.002	.002	56C/48Y
180	90	12	3600	10.5	.023	.002	.002	.002	.002	182C/143TC 184C/145TC
210	90	32	3600	27	.081	.016	.016	.016	.007	213C/182TC 215C/184TC

3. Select Options

Warner Electric Enclosed UniModules can be fitted with several accessories to extend their capacity and ease of mounting.

4. Select Control

All electrically released modules require a control with a potentiometer that will vary brake channel output. For FBB and MBFB brake modules, the CBC-160, CBC-200, CBC-300, or CBC-500/550 is recommended. The FBC units require either a CBC-300 or a CBC 500/550 control.

Selection Procedure

Note: Care must be exercised when selecting the proper brake size for your application.

The selection charts list NEMA motor frame sizes, motor shaft diameters, and the matching FBB or MBFB brakes.

To select a brake:

1. Determine the motor NEMA C-face frame size.
2. Select brake configuration
 - a. FBB to mount between a NEMA C-face motor and a gear reducer.
 - b. MBFB to mount on double shafted NEMA C-face motors.
3. Select the brake model from the charts by the torque required – higher torque for faster stopping, lower torque for longer, “soft” stopping.

Note: Size 100 brakes are typically used on motors with a rating of 1 HP or greater.

4. **Important:** Verify that the motor shaft diameter and mounting bolt circle dimensions are the same for the brake selected and the motor.

Control Selection

An optional conduit box enclosure is available. All electrically released units require a control with a potentiometer to vary brake channel output. For FBB and MBFB brake modules, control models CBC-160, CBC-200, CBC-300, or CBC-500/550 are recommended. (See Controls Section.)

Frame Size

EUM Size	NEMA Frame Size	Bolt Hole Mounting Circle	FBB Motor to Reducer Shaft Dia.	MBFB Motor Brake Shaft Dia.
EUM-50	56C	5 7/8	5/8	5/8
EUM-100	56C	5 7/8	5/8	5/8
EUM-180	143TC 145TC	5 7/8	7/8	7/8
EUM-210-7/8	213TC 215TC	7 1/4	N/A	7/8
EUM-210	182TC 184TC	7 1/4	1 1/8	1 1/8
EUM-215	213TC 215TC	7 1/4	1 3/8	N/A

How to Order

1. Specify model number and voltage or the corresponding part number.
2. Specify conduit box, if desired. See the Controls Section.
3. Specify required control unit. See the Controls Section.

Ordering Example

EUM-50-20FBB-6, 90V or 5370-169-983; 5370-101-042 conduit box; CBC-160-2 control.

EUM Description	EUM Model No.	Static Torque (lb.ft.)	Part No.	
FBB Brake Module (90VDC)	EUM-50-20FBB-6	6	5370-169-983	
	EUM-50-20FBB-10	10.5	5370-169-986	
	EUM-100-20FBB-12	12	5370-169-989	
	EUM-100-20FBB-21	21	5370-169-992	
	EUM-180-20FBB-12	12	5370-169-995	
	EUM-180-20FBB-21	21	5370-169-998	
	EUM-210-20FBB-32	32	5371-169-078	
	EUM-210-20FBB-56	56	5371-169-082	
	EUM-215-20FBB-32	32	5371-169-086	
	EUM-215-20FBB-56	56	5371-169-090	
	MBFB Motor Brake Module (90VDC)	EUM-50-20MBFB-6	6	5370-169-965
		EUM-50-20MBFB-10	10.5	5370-169-968
		EUM-100-20MBFB-12	12	5370-169-971
		EUM-100-20MBFB-21	21	5370-169-974
EUM-180-20MBFB-12		12	5370-169-977	
EUM-180-20MBFB-21		21	5370-169-980	
EUM-210-7/8-20MBFB-32		32	5371-169-064	
EUM-210-7/8-20MBFB-56		56	5371-169-068	
EUM-210-20MBFB-32		32	5371-169-056	
EUM-210-20MBFB-56		56	5371-169-060	

Accessories

Description	FBB Size	Part No.
Conduit Box	FBB series All sizes	5370-101-042
Motor Mount Kit for 20 FBB	50/100/180	5370-101-012
	210/215	5371-101-012

EUM-FBB Brake Module

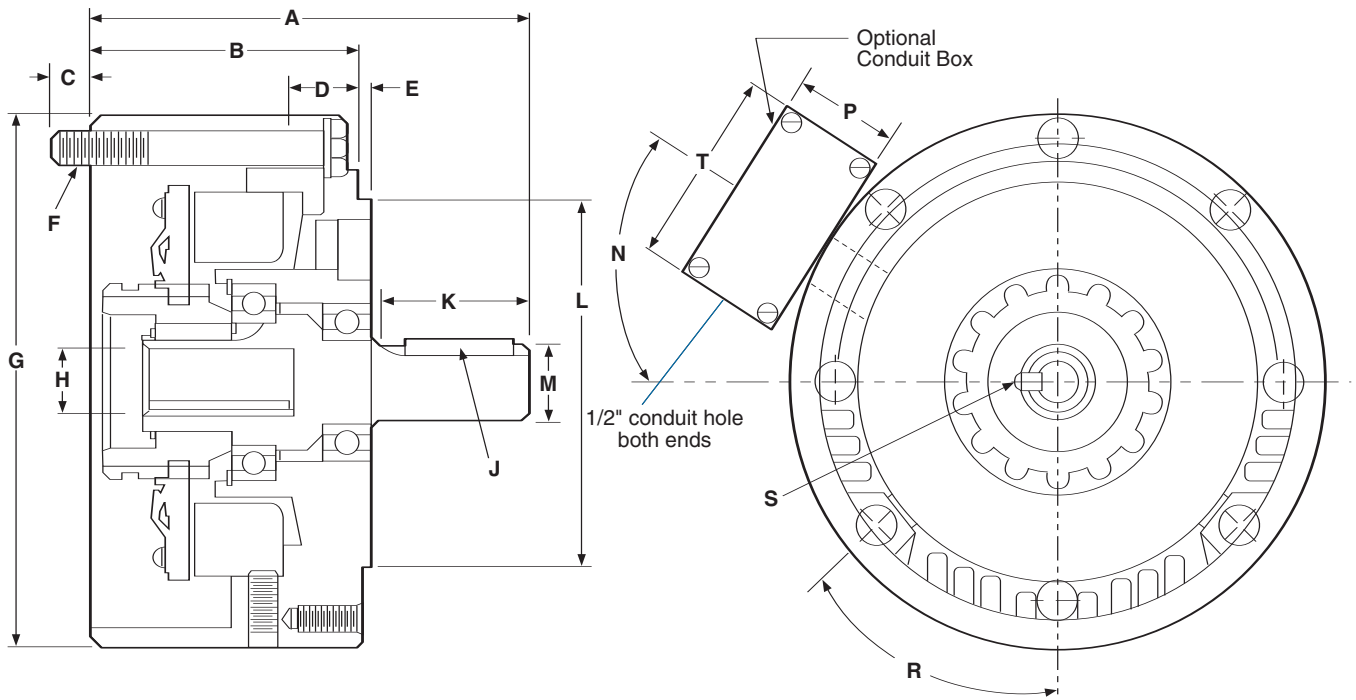

All dimensions are nominal, unless otherwise noted.

Size	A Max.	B	C Max.	D	E Max.	F	G Dia.	H Dia.
50	5.188	3.125	.500	1.000	.156	3/8-16 UNC-2A (4) Equally Spaced on 5.875 Dia.	6.688	.625
100	5.266	3.125	.500	1.000	.156	3/8-16 UNC-2A (4) Equally Spaced on 5.875 Dia.	6.688	.625
180	5.266	3.125	.500	1.000	.156	3/8-16 UNC-2A (4) Equally Spaced on 5.875 Dia.	6.688	.875
210	7.578	4.609	.594	1.500	.313	1/2-13 UNC-2A (4) Equally Spaced on 7.250 Dia.	9.344	1.125
215	7.578	4.609	.594	1.500	.313	1/2-13 UNC-2A (4) Equally Spaced on 7.250 Dia.	9.344	1.375

Size	J Key	K Min.	L Pilot Dia.	M Dia.	N	P	R	S Integral Key	T
50	3/16 x 3/16 x 1-1/4	1.813	4.500	.625	30°	2.188	45°	3/16 x 3/16	3.125
100	3/16 x 3/16 x 1-1/4	1.891	4.500	.625	30°	2.188	45°	3/16 x 3/16	3.125
180	3/16 x 3/16 x 1-1/4	1.891	4.500	.875	30°	2.188	45°	3/16 x 3/16	3.125
210	1/4 x 1/4 x 2	2.500	8.500	1.125	25°	2.188	45°	1/4 x 1/4	3.125
215	5/16 x 5/16 x 2	2.500	8.500	1.375	25°	2.188	45°	5/16 x 5/16	3.125

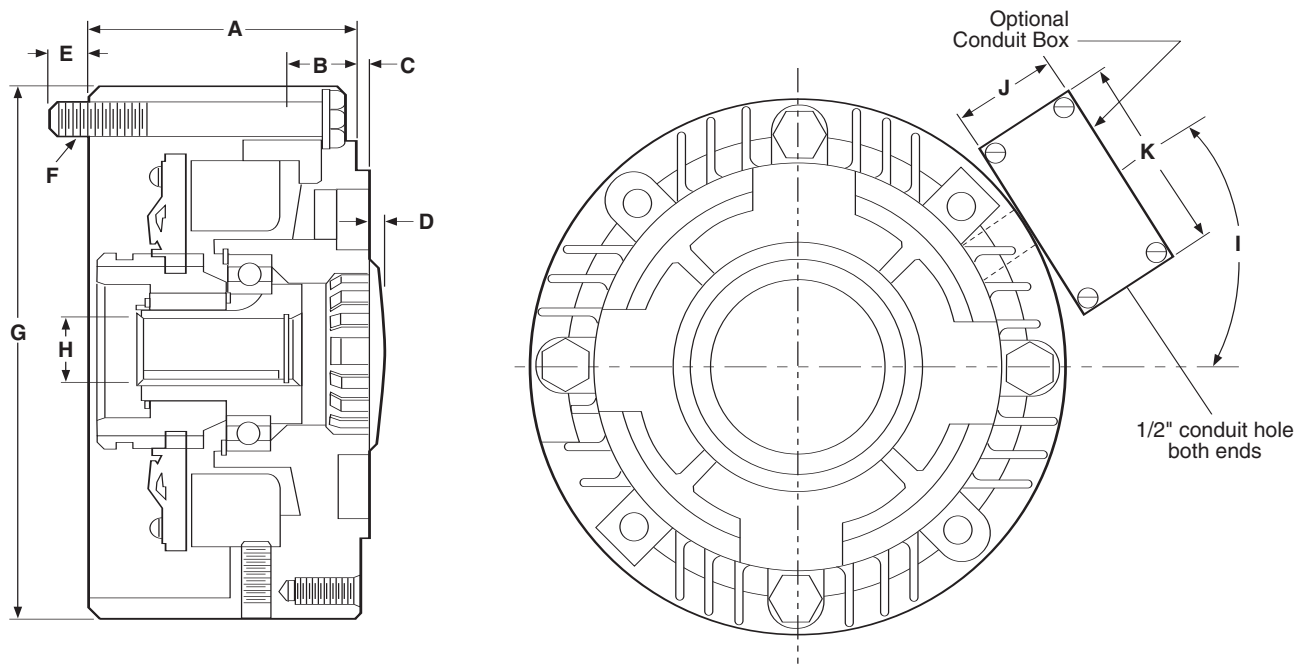

All dimensions are nominal, unless otherwise noted.

Size	A	B	C Max.	D	E Max.	F	G Dia.	Dia.	H Max. Length	Integral Key	I	J	K
50	3.125	1.000	.156	.219	.300	3/8-16 UNC-2A	6.688	.625	2.094	3/16 x 3/16	30°	2.188	3.125
100	3.125	1.000	.156	.219	.300	3/8-16 UNC-2A	6.688	.625	2.094	3/16 x 3/16	30°	2.188	3.125
180	3.125	1.000	.156	.219	.500	3/8-16 UNC-2A	6.688	.875	2.063	3/16 x 3/16	30°	2.188	3.125
210-7/8"	4.609	1.500	.313	.250	.594	1/2-13 UNC-2A	9.344	.875	2.766	3/16 x 3/16	30°	2.188	3.125
210	4.609	1.500	.313	.250	.594	1/2-13 UNC-2A	9.344	1.125	2.766	1/4 x 1/4	30°	2.188	3.125

Electro Module, Electrically Released Brakes and Clutch/Brake Units for Dynamic Stopping and Cycling Applications

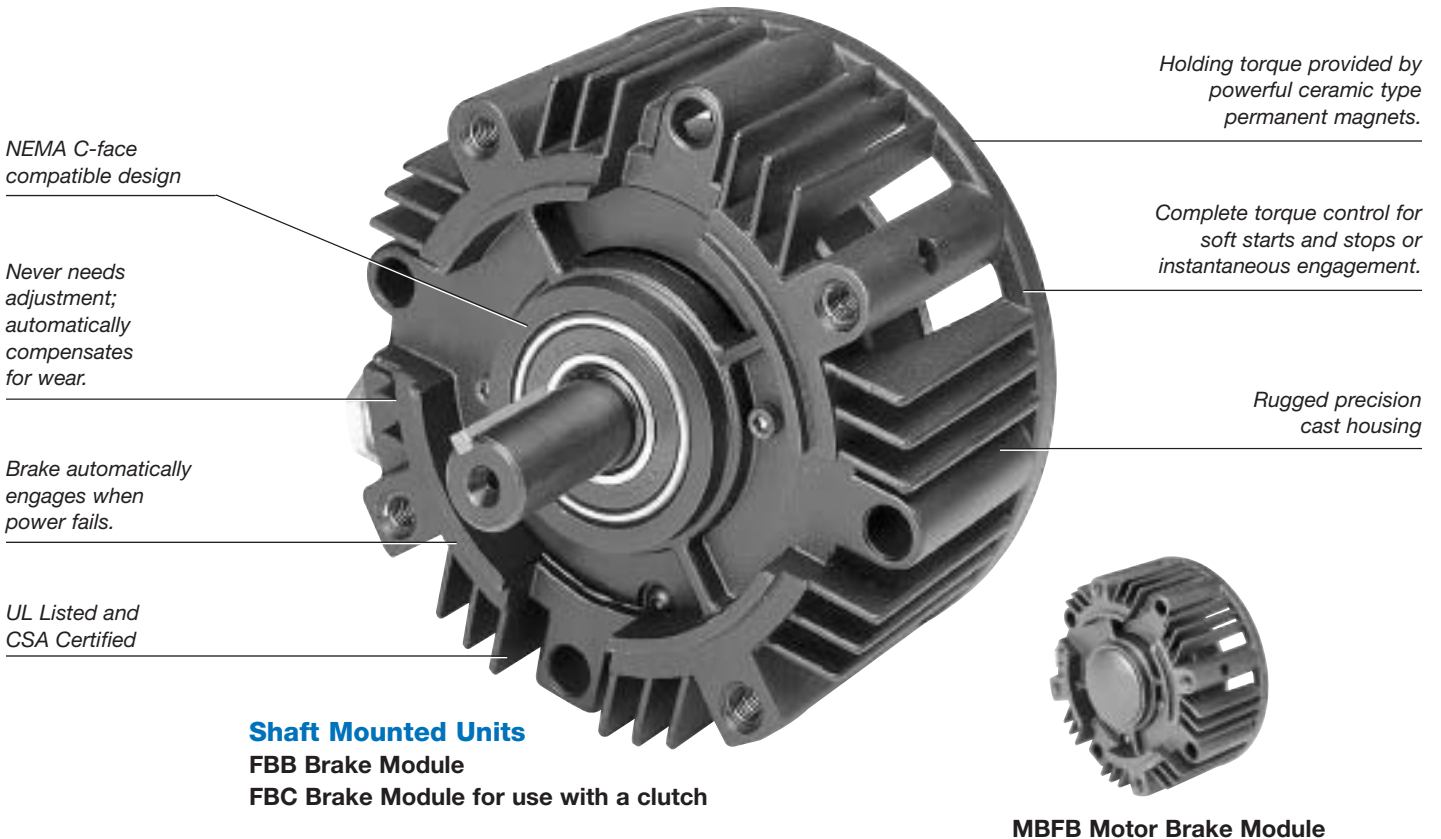

Warner Electric's unique design employs powerful permanent magnets for maximum torque when power is removed from the brake coil. A small amount of electrical power applied to the brake coil nullifies the permanent magnets' force and the brake releases. No springs to limit cycle rates. Never nay adjustment. No lubrication. These brakes are recommended for dynamic cycling operations only.

Available in Three Design Styles

EM-FBB Brake Module

Use for brake alone applications. Mounts between a C-face motor and a gear box or reducer. Available in five sizes.

EM-MBFB Motor Brake Module

Mounts to the back of a double shafted motor. Available in four sizes.

EM-FBC Brake Module for use with a Clutch

Combine with a motor or input clutch for clutch/brake applications. Three sizes are available.

Specifications

Size	Voltage DC	Static Torque (lb.ft.)		Max. Speed (RPM)	Total Weight (lbs.)	Component Inertia -WR ² (lb.ft. ²)			NEMA Frame Size	
		Brake	Clutch			Armature		Hub		Shaft
EM-50	24 90	10.5	16	3600	8.6	.0071	.014	.003	.001	56C/48Y
EM-100	90	21	—	3600	10.5	.018	—	.004	.002	56C/48Y
EM-180	24 90	21	30	3600	10.5	.018	.036	.004	.002	182C/143TC 184C/145TC
EM-210	24 90	56	95	3600	27	.081	.162	.027	.017	213C/182TC 215C/184TC

Warner Electric Electrically Released Electro Modules are available in three styles. The EM-FBB Brake Module is used in brake only applications and mounts between a C-face motor and a gear box or reducer. The EM-MBFB Motor Brake Module mounts to the back of a double shafted motor. The EM-FBC Brake Module is combined with a motor clutch (EM-10) or an input clutch (EM-30) for clutch/electrically released brake applications.

Note: Care must be exercised when selecting a brake to ensure it is sized properly for your application.

1. Select Configuration

a. For FBB and MBFB Modules NEMA C-face Mounting

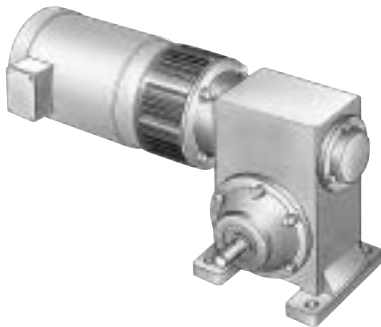

Verify that the brake will be cycled frequently.

Determine the NEMA C-face frame size of your motor and/or reducer, and choose the corresponding size Electro Module from the Frame Size Selection chart.

Size EM-100 modules utilize a 5/8" diameter shaft to fit 56C/48Y motor frames with components of EM-180 units for higher torque and heat dissipation capacity than the EM-50

Select Brake Configuration: use an EM-FBB for mounting between a motor and a reducer; or an EM-MBFB for mounting on the rear of a double shafted motor. NOTE: When selecting an MBFB, ensure the shaft dimensions on the rear of the motor are compatible with the EM-MBFB unit selected.

b. For FBC Modular Units, NEMA C-face Mounting

Verify that brake will be cycled frequently, and will be used with a motor mounted clutch (EM-10) for C-face mounting.

Determine the NEMA C-face frame size of your motor and/or reducer, and choose the corresponding size Electro Module from the Frame Size Selection chart.

FBC Frame Size Selection

NEMA Frame Size	EM Size
56C/48Y	EM-50* EM-100**
182C/143TC 184C/145TC	EM-180
213C/182TC 215C/184TC	EM-210

For torque ratings, refer to the "Specifications" chart. Note that separate torque ratings are listed for the clutch and brake segments of the module.

* For 56C/48Y C-frame motors 3/4 HP and smaller, the EM-100 size may be used where extended life is desirable.

** The EM-100 size is recommended for motors 1 HP and larger.

c. For FBC Modular Units, Base Mounting



Verify that brake will be cycled frequently, and will be used with an input clutch (EM-30) for base mounting.

Select the correct size module from the Horsepower vs. Shaft Speed chart (at the bottom of this page) by determining the motor horsepower and RPM at the module location. The correct size EM is shown at the intersection of the HP and operating speed. For additional sizing information, refer to the technical sizing procedure (step 2).

FBB AND MBFB Frame Size Selection

NEMA Frame Size	EM Size
56C/48Y	EM-50* EM-100**
182C/143TC 184C/145TC	EM-180
213C/182TC 215C/184TC	EM-210
213TC/215TC	EM-215

*For 56C/48Y C-frame motors 3/4 HP and smaller, the EM-100 size may be used where extended life is desirable.

**The EM-100 size is recommended for motors 1 HP and larger.

Horsepower vs. Shaft Speed

HP	SHAFT SPEED AT CLUTCH (IN RPM)																		
	100	200	300	400	500	600	700	800	900	1000	1100	1200	1500	1800	2000	2400	3000	3600	
1/4																			
1/2																			
3/4																			
1																			
1-1/2																			
2																			
3																			
5																			
7-1/2																			

2. Determine Technical Requirements

Technical considerations for sizing and selection are torque and heat dissipation. Each merits careful consideration, especially heat dissipation as over time, use in excessive temperature environments will have an adverse effect on bearing life and coil wire insulation integrity.

Compare the calculated torque requirement with the average dynamic torque ratings. Select a unit with adequate torque. If the unit selected on torque is different than the unit selected based on heat, select the larger size unit.

a. Heat Dissipation Sizing

Friction surfaces slip during the initial period of engagement and, as a result, heat is generated. The clutch/brake selected must have a heat dissipation rating greater than the heat generated by the application. Therefore, in high inertia or high cycle rate applications, it is necessary to check the heat dissipation carefully. Inertia, speed and cycle rate are the required parameters.

Heat dissipation requirement is calculated as follows:

$$E = 1.7 \times WR^2 \times (N/100)^2 \times F$$

where:

$$E = \text{Heat (lb. ft./min.)}$$

WR^2 = Total reflected inertia at the clutch/brake shaft. Include the clutch/brake output inertia. (lb.ft.²)

N = Speed in revolutions per minute. (RPM)

F = Cycle rate in cycles per minute (CPM)

Compare the calculated heat generated in the application to the unit ratings using the heat dissipation curves. Select the appropriate unit that has adequate heat dissipation ability.

Heat Dissipation Curves

Size 50

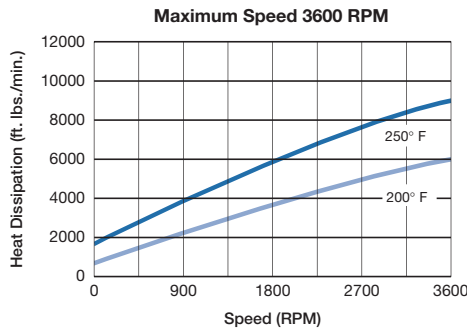

Size 100/180

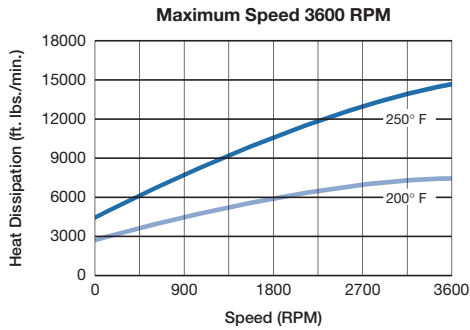

Size 210/215

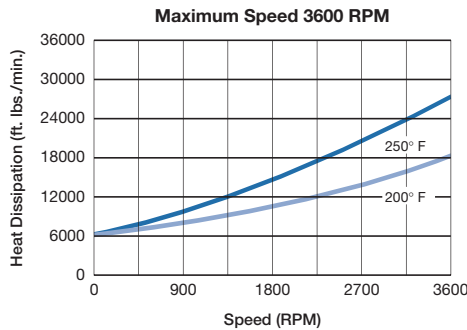

b. Torque Sizing

For most applications, the correct size clutch/brake can be selected from the Horsepower vs. Shaft Speed chart on page 131. Determine the motor horsepower and the RPM at the clutch/brake. The correct size unit is shown at the intersection of horsepower and shaft speed.

If the static torque requirements are known, refer to the technical ratings chart to select a unit.

For some applications, the torque requirement is determined by the time allowed to accelerate and decelerate the load. (This time is generally specified in milliseconds.) For these applications, it is necessary to determine the torque requirement based on load inertia and the time allowed for engagement.

The torque requirements are calculated as follows:

$$T = (WR^2 \times N) / (308 \times t)$$

where:

T = Average Dynamic Torque (lb. ft.)

WR^2 = Total reflected inertia at the clutch/brake shaft. Include the clutch/brake output inertia. (lb. ft.²)

N = Speed in revolutions per minute. (RPM)

t = Time allowed for the engagement (sec)

C-face Electrically Released Brakes Dynamic Torque Curves

Size 50

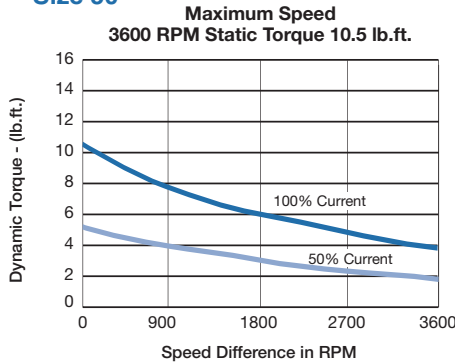

Size 100/180

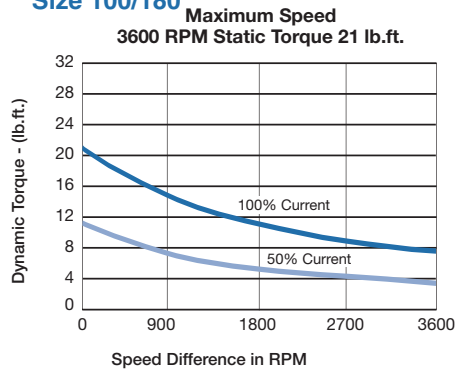

Size 210/215

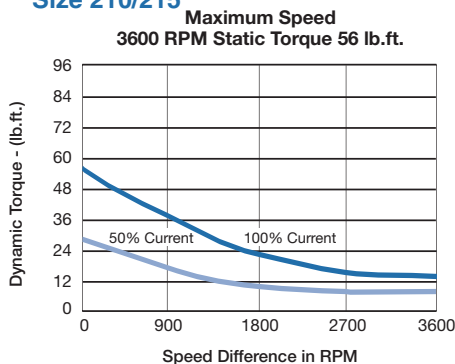

3. Select Accessories

Warner Electric Electro Modules can be fitted with several accessories to extend their capacity and ease of mounting.

4. Select Control

All electrically released modules require a control with a potentiometer that will vary brake channel output. For FBB and MBFB brake modules, the CBC-160, CBC-200, CBC-300, or CBC-500/550 is recommended. The FBC units require either a CBC-300 or a CBC 500/550 control.

How to Order

1. Specify model number and voltage or the corresponding part number.
2. Specify conduit box, if desired. See the Controls Section.
3. Specify required control. See the Controls Section.

Ordering Example

EM-50-20FBB, 90V or 5370-169-058;
5370-101-042 conduit box; CBC-160-2 control.

EM Description	EM Model No.	Voltage DC	Part No.
FBB Brake Module for use as brake only	EM-50-20FBB	24	5370-169-066
	EM-50-20FBB	90	5370-169-058
	EM-100-20FBB	24	5370-169-020
	EM-100-20FBB	90	5370-169-084
	EM-180-20FBB	24	5370-169-068
	EM-180-20FBB	90	5370-169-059
	EM-210-20FBB	24	5371-169-032
	EM-210-20FBB	90	5371-169-029
	EM-215-20FBB	24	5371-169-100
	EM-215-20FBB	90	5371-169-054
FBC Brake Module for use with EM clutch	EM-50-20FBC	24	5370-169-065
	EM-50-20FBC	90	5370-169-056
	EM-100-20FBC	24	5370-169-109
	EM-100-20FBC	90	5370-169-108
	EM-180-20FBC	24	5370-169-067
	EM-180-20FBC	90	5370-169-057
MBFB Motor Brake Module	EM-210-20FBC	24	5371-169-031
	EM-210-20FBC	90	5371-169-028
	EM-50-20MBFB	24	5370-169-063
	EM-50-20MBFB	90	5370-169-060
	EM-100-20MBFB	24	5370-169-007
	EM-100-20MBFB	90	5370-169-085
	EM-180-20MBFB	24	5370-169-069
	EM-180-20MBFB	90	5370-169-061
	EM-210-7/8-20MBFB	24	5371-169-101
	EM-210-7/8-20MBFB	90	5371-169-072
EM-210-20MBFB	24	5371-169-033	
EM-210-20MBFB	90	5371-169-030	

Accessories

Description	EM Size	Part No.
Conduit Box	EM series	5370-101-042
	All sizes	
Base Mount Kit for 2030 FBC	50/100	5370-101-036
	180	5370-101-037
	210/215	5371-101-019
Motor Mount Kit for 20 FBB, 1020 FBC	50/100	5370-101-010
	180	5370-101-012
	210/215	5371-101-012

EM-20 FBB Brake Module

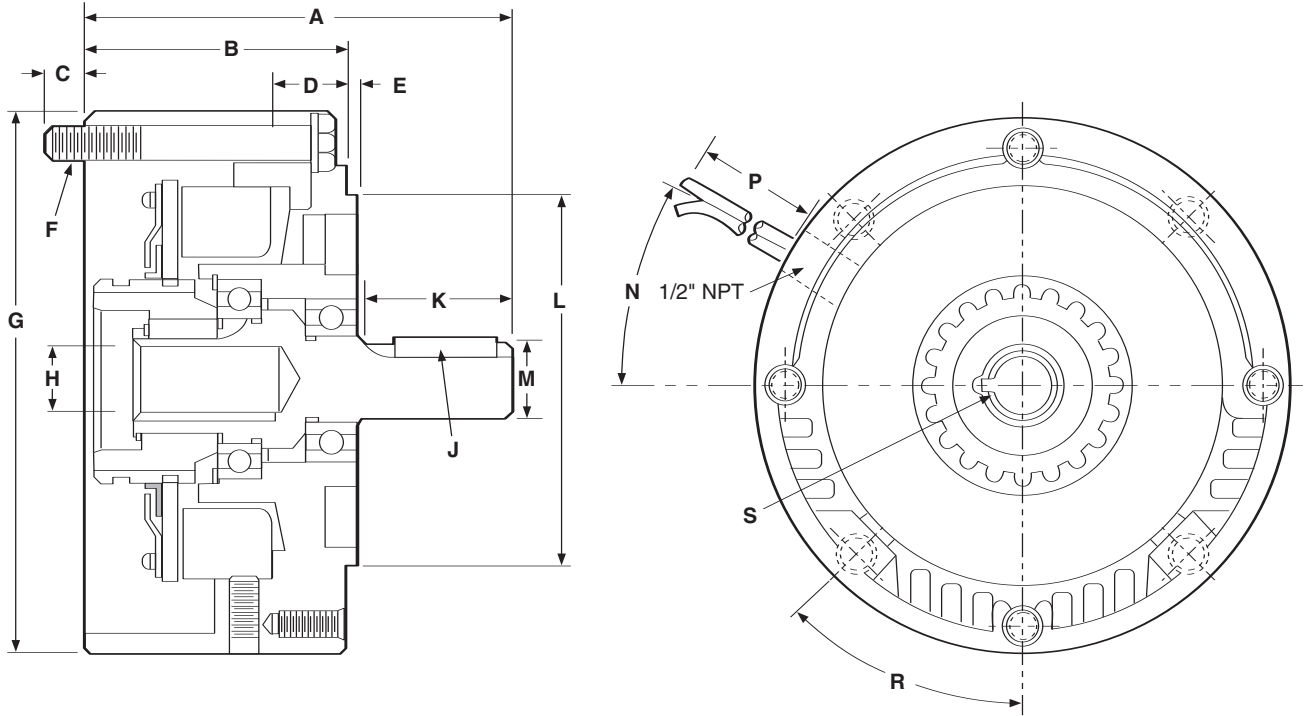

All dimensions are nominal, unless otherwise noted.

Size	A Max.	B	C Max.	D	E Max.	F	G Dia.	H Dia.	J	K Min.	L Pilot Dia.	M Dia.	N	P Min.	R	S Key
50/100	5.188	3.125	.500	1.000	.156	3/8-16 UNC-2A (4) Equally Spaced on 5.875 Dia.	6.688	.625	3/16 x 3/16 x 1-3/8	1.813	4.500	.625	30°	36	45°	3/16 x 3/16
180	5.266	3.125	.500	1.000	.156	3/8-16 UNC-2A (4) Equally Spaced on 5.875 Dia.	6.688	.875	3/16 x 3/16 x 1-3/8	1.891	4.500	.875	30°	36	45°	3/16 x 3/16
210	7.578	4.609	.594	1.500	.313	1/2-13 UNC-2A (4) Equally Spaced on 7.250 Dia.	9.344	1.125	1/4 x 1/4 x 2	2.500	8.500	1.125	25°	36	45°	1/4 x 1/4
215	7.578	4.609	.594	1.500	.313	1/2-13 UNC-2A (4) Equally Spaced on 7.250 Dia.	9.344	1.375	5/16 x 5/16 x 2	2.500	8.500	1.375	25°	36	45°	5/16 x 5/16

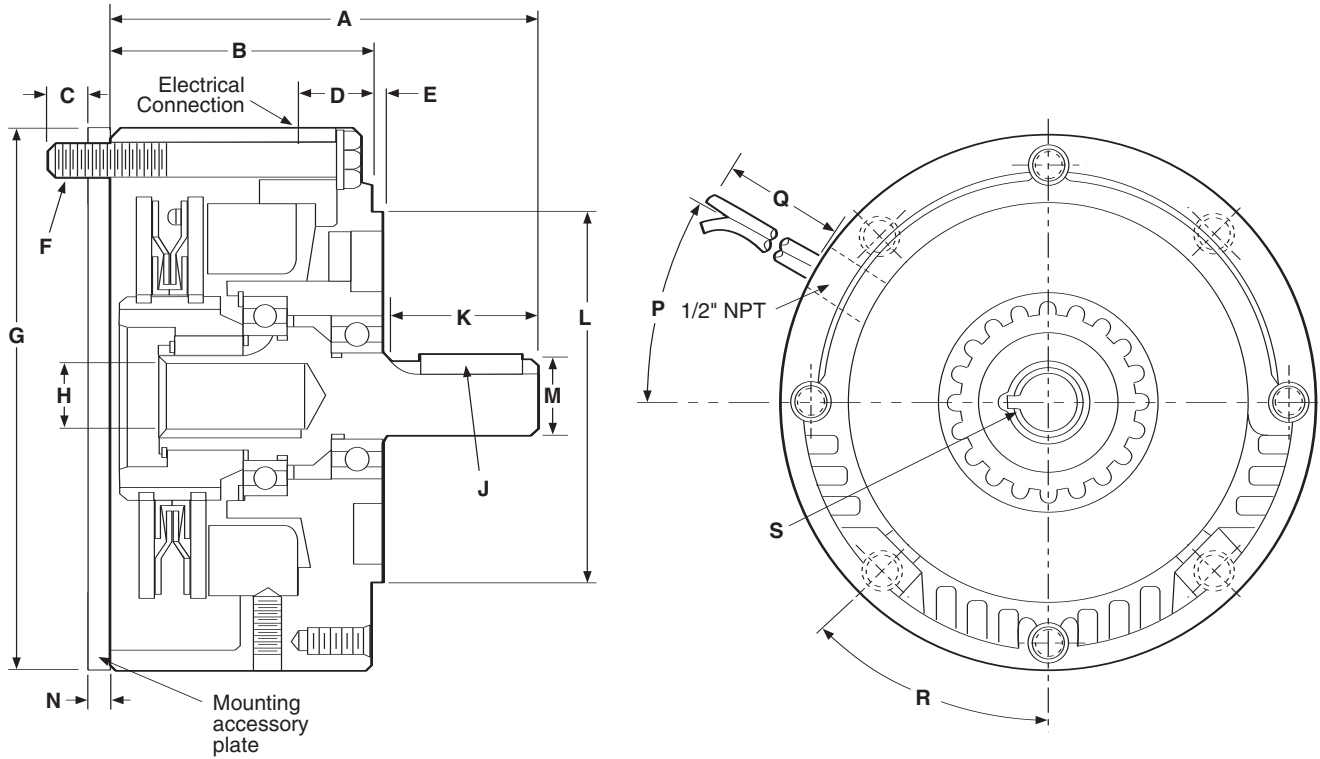

All dimensions are nominal, unless otherwise noted.

Size	A Max.	B	C Max.	D	E Max.	F	G Dia.	H Dia.	J	K Min.	L Pilot Dia.	M Dia.	N Max.	P	Q Min.	R	S Key
50/100	5.188	3.125	.500	1.000	.156	3/8-16 UNC-2A (4) Equally Spaced on 5.875 Dia.	6.688	.625	3/16 x 3/16 x 1-3/8	1.813	4.500	.625	.531	30°	36	45°	3/16 x 3/16
180	5.266	3.125	.500	1.000	.156	3/8-16 UNC-2A (4) Equally Spaced on 5.875 Dia.	6.688	.875	3/16 x 3/16 x 1-3/8	1.891	4.500	.875	.531	30°	36	45°	3/16 x 3/16
210	7.578	4.609	.594	1.500	.313	1/2-13 UNC-2A (4) Equally Spaced on 7.250 Dia.	9.344	1.125	1/4 x 1/4 x 2	2.500	8.500	1.125	.797	25°	36	45°	1/4 x 1/4

EM-20 MBFB Motor Brake Module

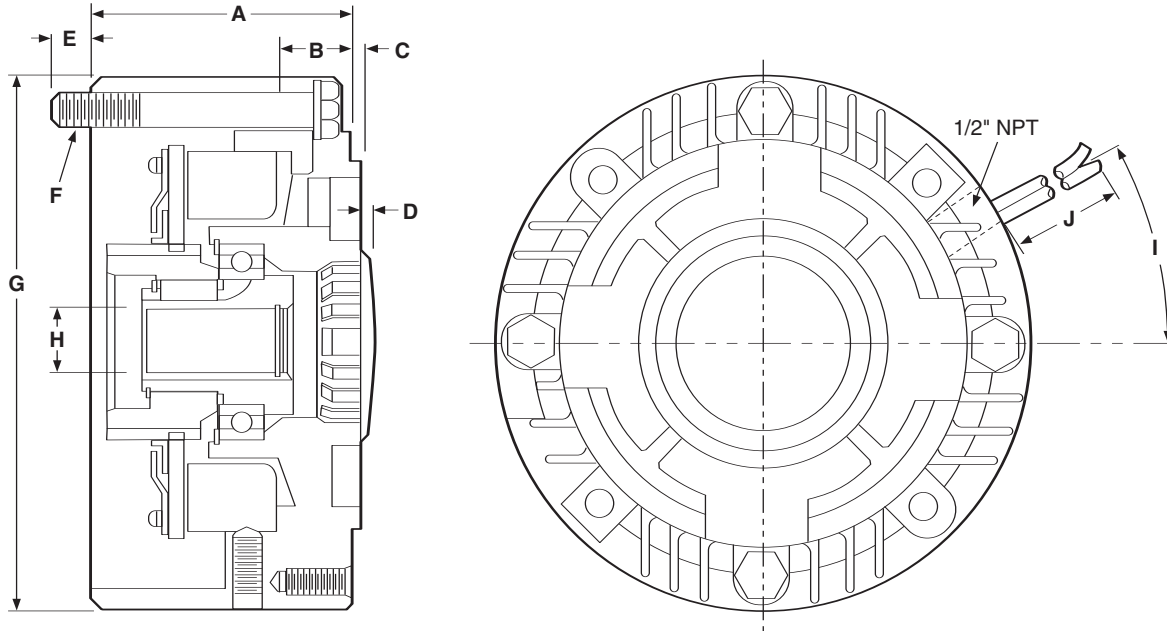

All dimensions are nominal, unless otherwise noted.

Size	A	B	C Max.	D	E Max.	F	G Dia.	H				
								Diameter	Max. Length	Required Key Size	I	J Min.
50/100	3.125	1.000	.156	.219	.300	3/8-16 UNC-2A	6.688	.625	2.094	3/16 x 3/16	30°	36
180	3.125	1.000	.156	.219	.500	3/8-16 UNC-2A	6.688	.875	2.063	3/16 x 3/16	30°	36
210-7/8"	4.609	1.500	.313	.250	.594	1/2-13 UNC-2A	9.344	.875	2.766	3/16 x 3/16	30°	36
210	4.609	1.500	.313	.250	.594	1/2-13 UNC-2A	9.344	1.125	2.766	1/4 x 1/4	30°	36

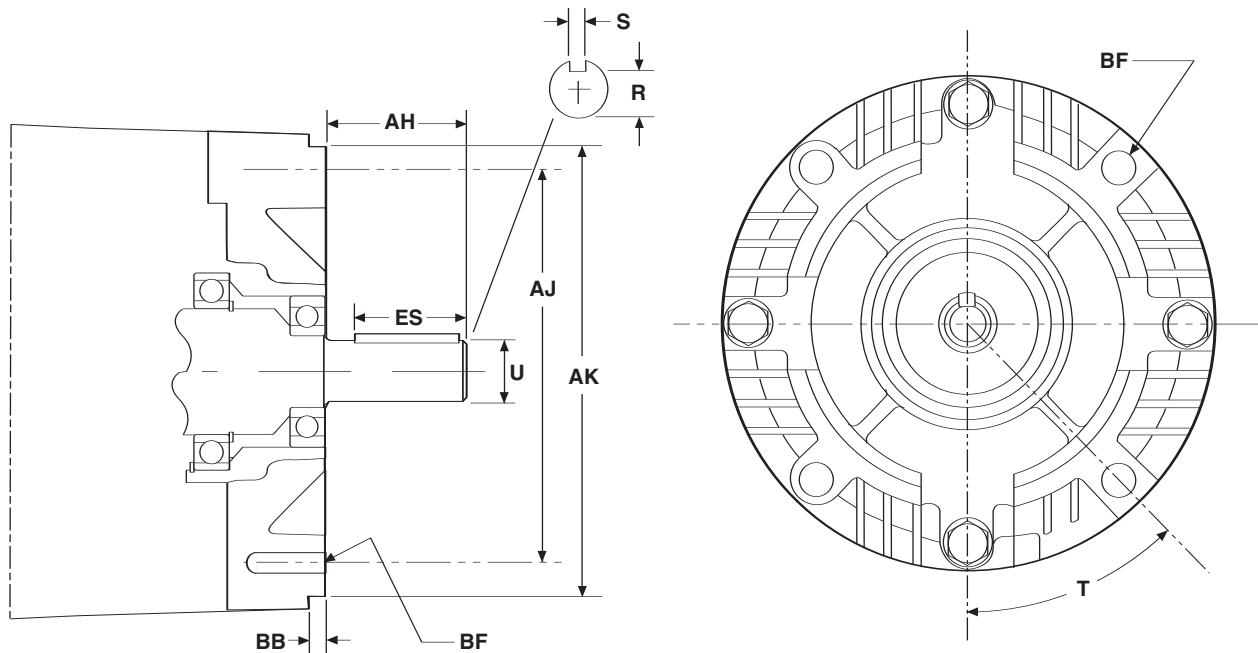

Specifications

Module Size	AH Shaft Length	AJ Mtg. Bolt Center Dia.	AK Mtg. Flange Pilot Dia.	BB Pilot Depth	BF Mtg. Bolt Size, Qty.	ES Keyway Length	R Depth Over Keyway	S Keyway Width	T Mtg. Bolt Ref.	U Shaft Dia.
50	2.06	5.875	4.500	5/32	3/8-16 UNC 4 @ 90°	1-1/4	.517	3/16	45°	.625
100	2.06	5.875	4.500	5/32	3/8-16 UNC 4 @ 90°	1-1/4	.517	3/16	45°	.625
180	2.04	5.875	4.500	5/32	3/8-16 UNC 4 @ 90°	1-1/4	.771	3/16	45°	.87 ⁵
210	2.56	7.250	8.500	5/16	1/2-13 UNC 4 @ 90°	2	.986	1/4	45°	1.125
215	3.12	7.250	8.500	5/16	1/2-13 UNC 4 @ 90°	2	1.201	5/16	45°	1.375

Note: Warner Electric Modules are designed to comply with the NEMA frame standards for mounting. Reference to each particular frame size is given in the individual selection tables for each type of Warner Electric module.

Electrical Data/Coil Ratings

EC/EB-375	EC			EB		
Voltage – DC	90	24	6	90	24	6
Resistance @ 20° C – Ohms	453.5	29.3	2.10	446.8	29.3	1.96
Current – Amperes	.198	.82	2.85	.201	.82	3.07
Watts	17	20	17	18	20	18
Coil Build-up – milliseconds	62	60	59	50	60	52
Coil Decay – milliseconds	13	14	15	8	14	10

EC/EB-475	EC			EB		
Voltage – DC	90	24	6	90	24	6
Resistance @ 20° C – Ohms	368.9	37.8	2.32	443.1	28.8	2.05
Current – Amperes	.244	.64	2.58	.203	.88	2.93
Watts	22	15	16	18	21	18
Coil Build-up – milliseconds	92	91	90	80	75	70
Coil Decay – milliseconds	18	17	16	8	9	9

EC/EB-650	EC			EB		
Voltage – DC	90	24	6	90	24	6
Resistance @ 20° C – Ohms	225	17.7	1.16	257.2	18.3	1.24
Current – Amperes	.4	1.36	5.19	.35	1.3	4.84
Watts	36	33	31	32	31	29
Coil Build-up – milliseconds	120	115	110	112	108	105
Coil Decay – milliseconds	20	20	20	12	13	14

FB/ER-375, 475, 650	FB-375		FB-475		FB-650	
Voltage – DC	90	24	90	24	90	24
Resistance @ 20° C – Ohms	446	29	310	22	235	16
Current – Amperes	.201	.822	.300	1.09	.380	1.426
Watts	18	19	27	26	34	34
Coil Build-up – milliseconds	40	40	80	80	90	90
Coil Decay – milliseconds	5	10	8	10	10	10

ER-825, 1225	ER-825		ER-1225	
Voltage – DC	90		35-75	
Resistance @ 20° C – Ohms	304		235	
Current – Amperes	.29		.383	
Watts	26		35	
Coil Build-up – milliseconds	400		700	
Coil Decay – milliseconds	20		20	

EC/EB-825	EC			EB		
Voltage – DC	90	24	6	90	24	6
Resistance @ 20° C – Ohms	221	20.9	1.098	223.3	20.4	1.27
Current – Amperes	.407	1.15	5.464	.4	1.18	4.74
Watts	37	28	33	36	28	28
Coil Build-up – milliseconds	225	200	180	170	170	170
Coil Decay – milliseconds	130	122	115	80	75	70

EC/EB-1000	EC			EB		
Voltage – DC	90	24	6	90	24	6
Resistance @ 20° C – Ohms	248.7	19.7	1.23	248.7	19.7	1.23
Current – Amperes	.36	1.22	4.87	.36	1.22	4.87
Watts	33	29	29	33	29	29
Coil Build-up – milliseconds	250	235	220	235	220	205
Coil Decay – milliseconds	70	75	80	70	75	80

EC/EB-1225	EC			EB		
Voltage – DC	90	24	6	90	24	6
Resistance @ 20° C – Ohms	207.3	15.1	1.04	261.7	22.3	1.33
Current – Amperes	.43	1.59	5.79	.34	1.08	4.5
Watts	39	38	35	31	26	27
Coil Build-up – milliseconds	500	490	480	460	445	435
Coil Decay – milliseconds	220	230	240	190	160	140

ATC, ATTC, ATB, ATTB-25	ATC			ATB		
Voltage – DC	6	24	90	6	24	90
Resistance @ 20° C – Ohms	1.37	20.2	290	1.37	20.2	290
Current – Amperes	4.38	1.19	.31	4.38	1.19	.31
Watts	26.3	28.6	27.9	26.3	28.6	27.9
Coil Build-up – milliseconds	145	145	145	145	145	145
Coil Decay – milliseconds	8	8	8	9	9	9

ATC, ATTC, ATB, ATTB-55	ATC			ATB		
Voltage – DC	6	24	90	6	24	90
Resistance @ 20° C – Ohms	1.21	19.6	230	1.21	19.6	230
Current – Amperes	4.96	1.22	.39	4.96	1.22	.39
Watts	29.8	29.3	35.2	29.8	29.3	35.2
Coil Build-up – milliseconds	200	200	200	210	210	210
Coil Decay – milliseconds	20	20	20	35	35	35

ATC, ATTC, ATB, ATTB-115	ATC			ATB		
Voltage – DC	6	24	90	6	24	90
Resistance @ 20° C – Ohms	1.02	16.5	182	1.02	16.5	182
Current – Amperes	5.91	1.46	.50	5.91	1.46	.50
Watts	35.4	35	44.6	35.4	35	44.6
Coil Build-up – milliseconds	145	145	145	150	150	150
Coil Decay – milliseconds	40	40	40	45	45	45

UM/EM/UMFB/EMFB								
		Clutch	UM/EM Brake	Clutch	Brake	Clutch	Brake	UMFB/EMFB Brake
		90	90	24	24	6	6	90
Voltage – DC	EM-50	452	452	31.8	31.8	1.86	1.86	446
Resistance	EM-100	392	392	26.7	26.7	1.80	1.80	310
(ohms)	EM-180	392	392	26.7	26.7	1.80	1.80	310
	EM-210/215	248	248	17.9	17.9	1.22	1.22	205
	EM-50	.199	.199	.755	.755	3.23	3.23	.210
Amperes	EM-100	.230	.230	.896	.896	3.30	3.30	.300
	EM-180	.230	.230	.896	.896	3.30	3.30	.300
	EM-210/215	.363	.363	1.34	1.34	4.90	4.90	.380
	EM-50	18	18	18	18	19	19	18
Watts	EM-100	21	21	21.5	21.5	20	20	27
	EM-180	21	21	21.5	21.5	20	20	27
	EM-210/215	33	33	32	32	30	30	34
	EM-50	52	53	52	53	52	53	40
Build-up	EM-100	72	75	72	75	72	70	80
(millisecond)	EM-180	72	75	72	75	72	70	80
	EM-210/215	120	100	120	100	110	100	90
	EM-50	6.2	5.0	6.2	5.0	6.5	5.0	5
Decay	EM-100	12	10	12	10	12	10	8
(millisecond)	EM-180	12	10	12	10	12	10	8
	EM-210/215	20	10	20	10	20	10	10