

UM-1020 FBC Motor Clutch/Electrically Released Brake

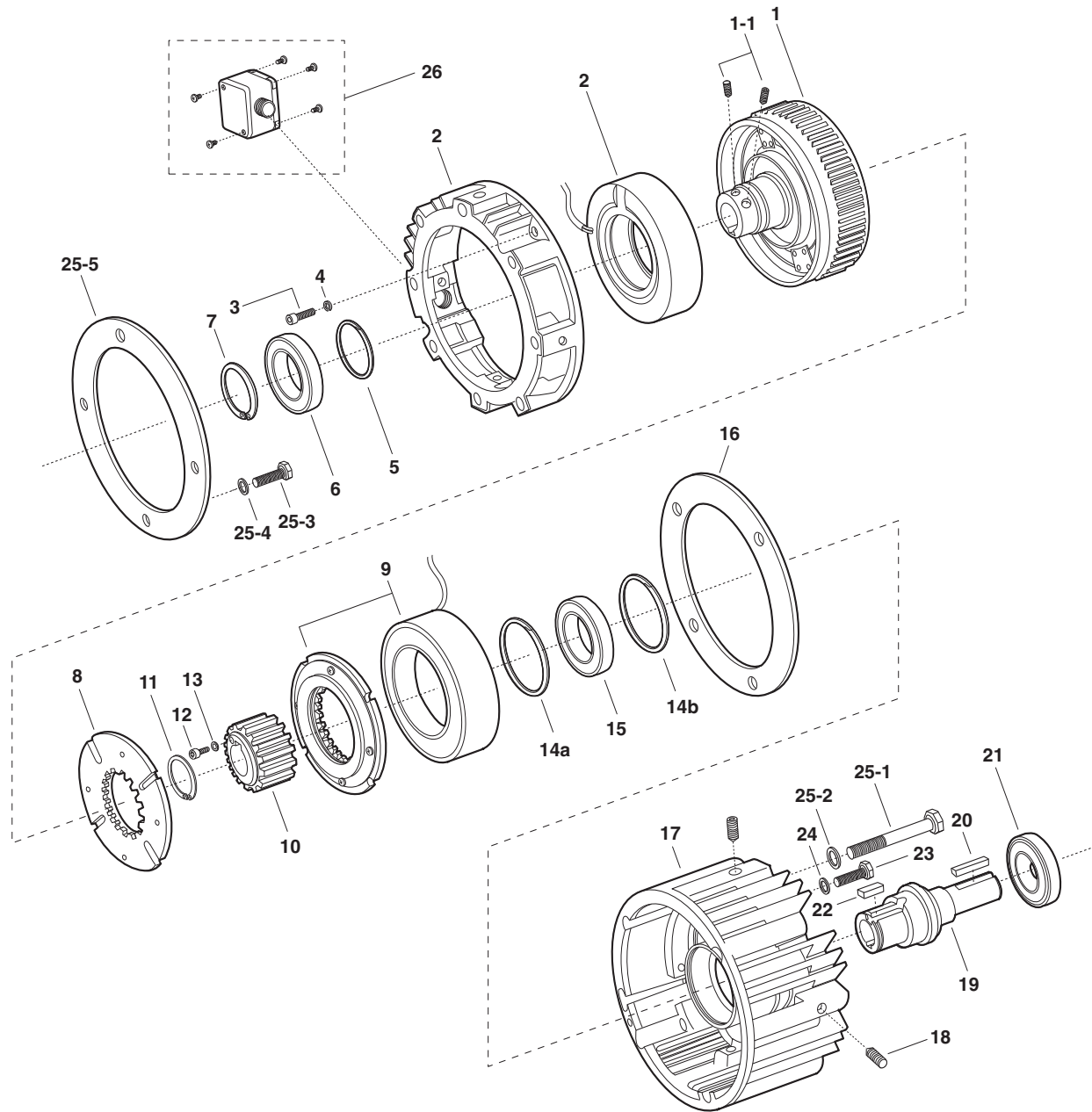

UM-1020 FBC Motor Clutch/Electrically Released Brake

Component Parts

Item	Description	UM-50		UM-100		UM-180		UM-210		UM-215	
		Part No.	Qty.	Part No.	Qty.	Part No.	Qty.	Part No.	Qty.	Part No.	Qty.
1	Rotor Assembly w/fan and hub	5370-751-019	1	5370-751-022	1	5370-751-017	1	5371-751-012	1	5371-751-031	1
	1-1 Setscrew	797-1098	2	797-0069	2	797-0069	2	797-1098	2	798-1098	2
2	Field w/housing		1		1		1		1		1
	24 volt	5370-451-064				5370-451-059		5371-451-029			
	90 volt	5370-451-063		5370-451-058		5370-451-058		5371-451-028		5371-451-028	
3	Capscrew	797-1451	2	797-1451	2	797-1451	1	797-1452	2	797-1452	2
4	Lockwasher	950-0436	4	950-0102	2	950-0436	5	950-0372	2	950-0102	2
5	Retaining Ring	748-0101	1	748-0101	1	748-0101	1	748-0558	1	748-0558	1
6	Ball Bearing	166-0150	1	166-0101	1	166-0101	1	166-0168	1	166-0168	1
7	Retaining Ring	748-0018	1	748-0101	1	748-0001	1	748-0067	1		
8	Armature	5370-111-011	1	5370-111-013	1	5370-111-013	1	5371-111-005	1	5371-111-005	1
9	Magnet and Armature (sold only in matched pairs)*		1		1		1		1		1
	24 volt	5370-6				5370-8		5371-3			
	90 volt	5370-1		5370-2		5370-2		5371-1		5371-1	
10	Armature Hub	540-1640	1	540-1644	1	540-1644	1	540-0835	1	540-2040	1
11	Retaining Ring	748-0445	1	748-0676	1	748-0676	1				
12	Capscrew							797-0081	6	797-0081	6
13	Lockwasher							950-0372	6	950-0372	6
14a	Retaining Ring	748-0113	1	748-0101	1	748-0101	1	748-0112	1	748-0112	1
14b	Retaining Ring	748-0113	1								
15	Ball Bearing	166-0149	1	166-0101	1	166-0101	1	166-0142	1	166-0142	1
16	Spacer	807-1085	1	807-1085	1	807-1085	1	807-1053	1	807-1053	1
17	Housing	535-0170	1	535-0171	1	535-0171	1	535-0172	1	535-0172	1
18	Setscrew	797-0471	4	797-0471	4	797-0471	4	797-0471	4	797-0471	1
19	Shaft	798-0046	1	798-0128	1	798-0085	1	798-0051	1	798-0254	1
20	Key	590-0029	1	590-0029	1	590-0029	1	590-0019	1	590-0124	1
21	Ball Bearing	166-0155	1	166-0143	1	166-0143	1	166-0144	1	166-0144	1
22	Key	590-0043	1	590-0084	1	590-0084	1				
23	Capscrew			797-1294	2	797-1294	2	797-0083	4	797-0083	4
24	Lockwasher							950-0372	4	950-0372	4
25	Mounting Accessory	5370-101-043	1	5370-101-043	1	5370-101-043	1	5371-101-039	1	5371-101-039	1
	25-1 capscrew	797-1440	4	797-1440	4	797-1440	4	797-1453	4		
	25-2 lockwasher	950-0354	4	950-0354	4	950-0354	4	950-0111	4		
	25-3 capscrew							797-1442	4		
	25-4 lockwasher							950-0101	4		
	25-5 adapter							104-0321	1		
26	Conduit Box (Optional)	5370-101-042	1	5370-101-042	1	5370-101-042	1	5370-101-042	1		
	Key for rotary assembly-not shown	5370-101-072	1	5370-101-072	1	5370-101-072	1	5371-101-043	1		

Refer to Service Manual P-213.

*Magnets and armatures sold only in pre-burnished sets to assure maximum torque is available upon installation.

UM-2030FBC Input Clutch/Electrically Released Brake

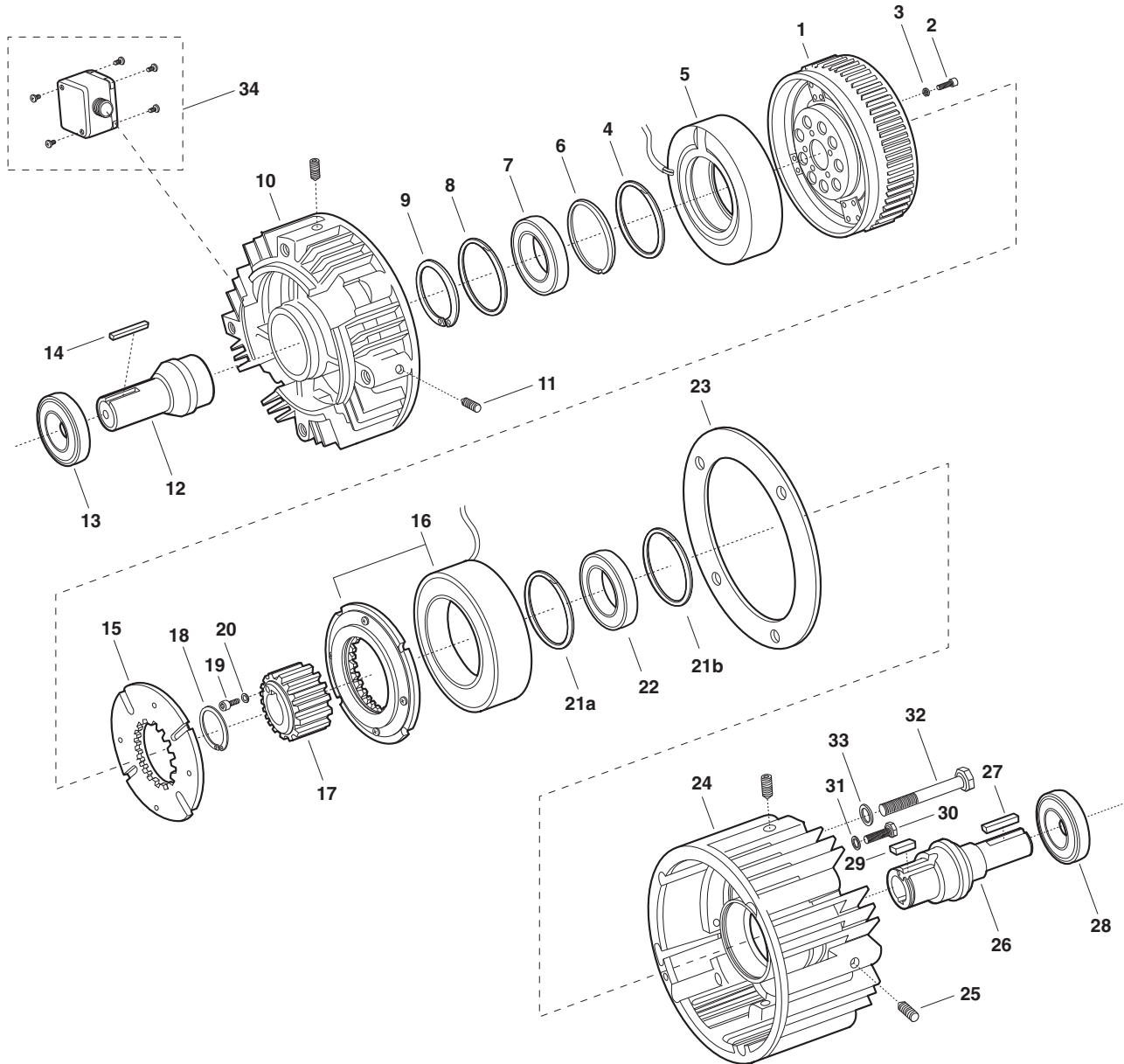

UM-2030FBC Input Clutch/Electrically Released Brake

Component Parts

Item	Description	UM-50		UM-180		UM-210	
		Part No.	Qty.	Part No.	Qty.	Part No.	Qty.
1	Rotor Assembly w/fan	5370-751-006	1	5370-751-009	1	5371-751-007	1
2	Capscrew	797-1294	4	797-1214	5	797-0083	6
3	Lockwasher	950-0436	4	950-0436	5	950-0372	6
4	Spacer			807-0062	1	807-0061	1
5	Field (with housing UM-50-20FBC only)		1		1		1
	24 volt	5370-451-074		5370-451-005		5371-451-005	
	90 volt	5370-451-073		5370-451-008		5371-451-003	
6	Retaining Ring	748-0113	1	748-0101	1	748-0112	1
7	Ball Bearing	166-0149	1	166-0101	1	166-0142	1
8	Retaining Ring	748-0113	1				
9	Retaining Ring	748-0017	1				
10	Housing			535-0164	1	535-0129	1
11	Setscrew			797-0471	4	797-0471	4
12	Shaft	798-0047	1	798-0124	1	798-0123	1
13	Bearing	166-0155	1	166-0143	1	166-0144	1
14	Key	590-0029	1	590-0029	1	590-0019	1
15	Armature Assembly	5370-111-011	1	5370-111-013	1	5371-111-005	1
16	Magnet and Armature (sold only in pairs)*		1		1		1
	24 volt	5370-6		5370-8		5371-3	
	90 volt	5370-1		5370-2		5371-1	
17	Armature Hub	540-1640	1	540-1644	1	540-0835	1
18	Retaining Ring	748-0445	1	748-0676	1		
19	Capscrew					797-0081	6
20	Lockwasher					950-0372	6
21a	Retaining Ring	748-0113	1	748-0101	1	748-0112	1
21b	Retaining Ring	748-0113	1	—		—	
22	Ball Bearing	166-0149	1	166-0101	1	166-0142	1
23	Spacer	807-1085	1	807-1085	1	807-1053	1
24	Housing	535-0170	1	535-0171	1	535-0172	1
25	Setscrew	797-0471	4	797-0471	4	797-0471	4
26	Shaft	798-0046	1	798-0085	1	798-0051	1
27	Key	590-0029	1	590-0029	1	590-0019	1
28	Ball Bearing	166-0155	1	166-0143	1	166-0144	1
29	Key	590-0043	1	590-0084	1		
30	Capscrew			797-1294	2	797-0083	4
31	Lockwasher					950-0372	4
32	Capscrew	797-0346	4	797-0346	4	797-1357	4
33	Lockwasher	950-0354	4	950-0354	4	950-0033	4
34	Conduit Box (Optional)	5370-101-042	1	5370-101-042	1	5370-101-042	1

Refer to Service Manual P-213.

*Magnets and armatures sold only in pre-burnished sets to assure maximum torque is available upon installation.

EM-20FBB Brake Module

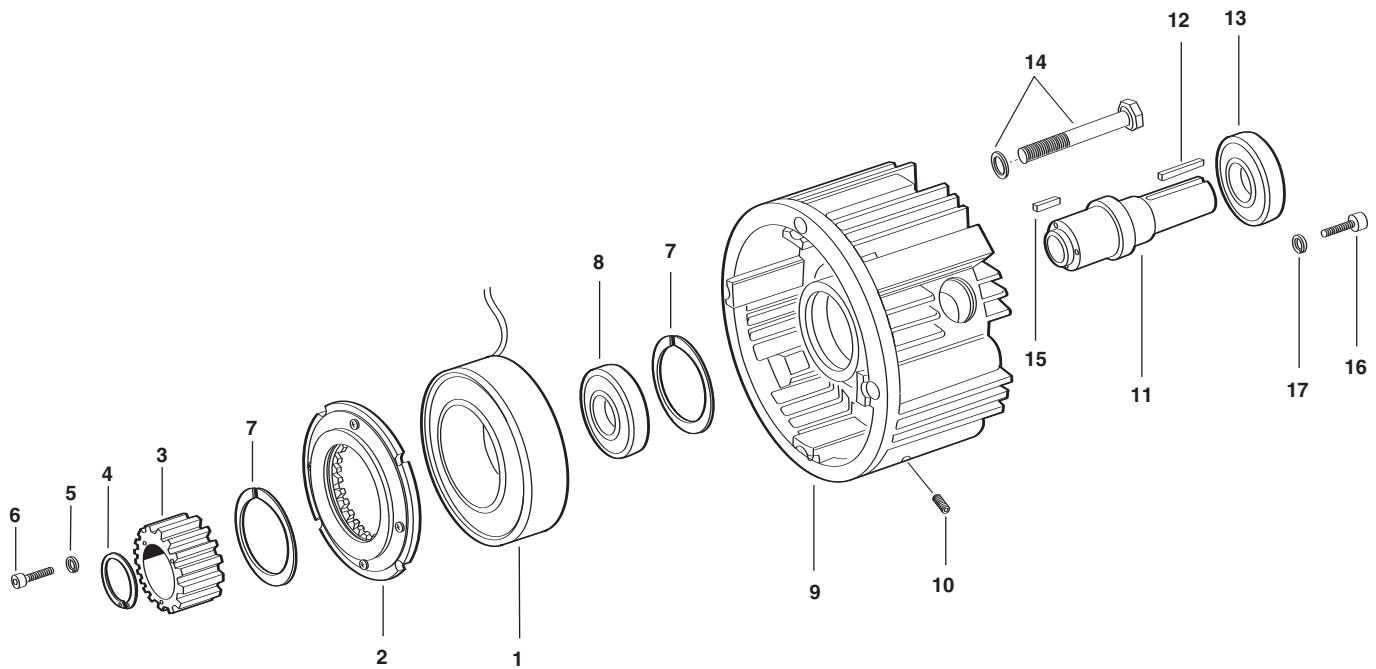

Component Parts

Item	Description	EM-50		EM-100		EM-180		EM-210	
		Part No.	Qty.	Part No.	Qty.	Part No.	Qty.	Part No.	Qty.
1 & 2	Magnet and Armature (sold only in matched pairs)* 24 volt 90 volt	5370-6 5370-1	1	5370-8 5370-2	1	5370-8 5370-2	1	5371-3 5371-1	1
3	Armature Hub	540-1638	1	540-1677	1	540-1642	1	540-0741	1
4	Retaining Ring	758-0445	1	748-0676	1	748-0676	1	748-0112	1
5	Lockwasher							950-0372	6
6	Capscrew							797-0081	6
7	Retaining Ring	748-0113	2	748-0101	1	748-0101	1		
8	Bearing	166-0149	1	166-0101	1	166-0101	1	166-0142	1
9	Housing	535-0130	1	535-0148	1	535-0148	1	535-0144	1
10	Setscrew	797-0471	4	797-0471	4	797-0471	4	797-0471	4
11	Shaft	5370-798-001	1	5370-798-005	1	5370-798-002	1	5371-798-001	1
12	Key	590-0029	1	590-0029	1	590-0029	1	590-0019	1
13	Bearing	166-0155	1	166-0143	1	166-0143	1	166-0144	1
14	Mounting Accessory	5370-101-017	1	5370-101-017	1	5370-101-017	1	5371-101-007	1
15	Key	590-0043	1	590-0084	1	590-0084	1		
16	Capscrew			797-1214	2	797-1214	2	797-0083	2
17	Lockwasher							950-0372	2

Refer to Service Manual P-213.

*Magnets and armatures sold only in pre-burnished sets to assure maximum torque is available upon installation.

Service Parts

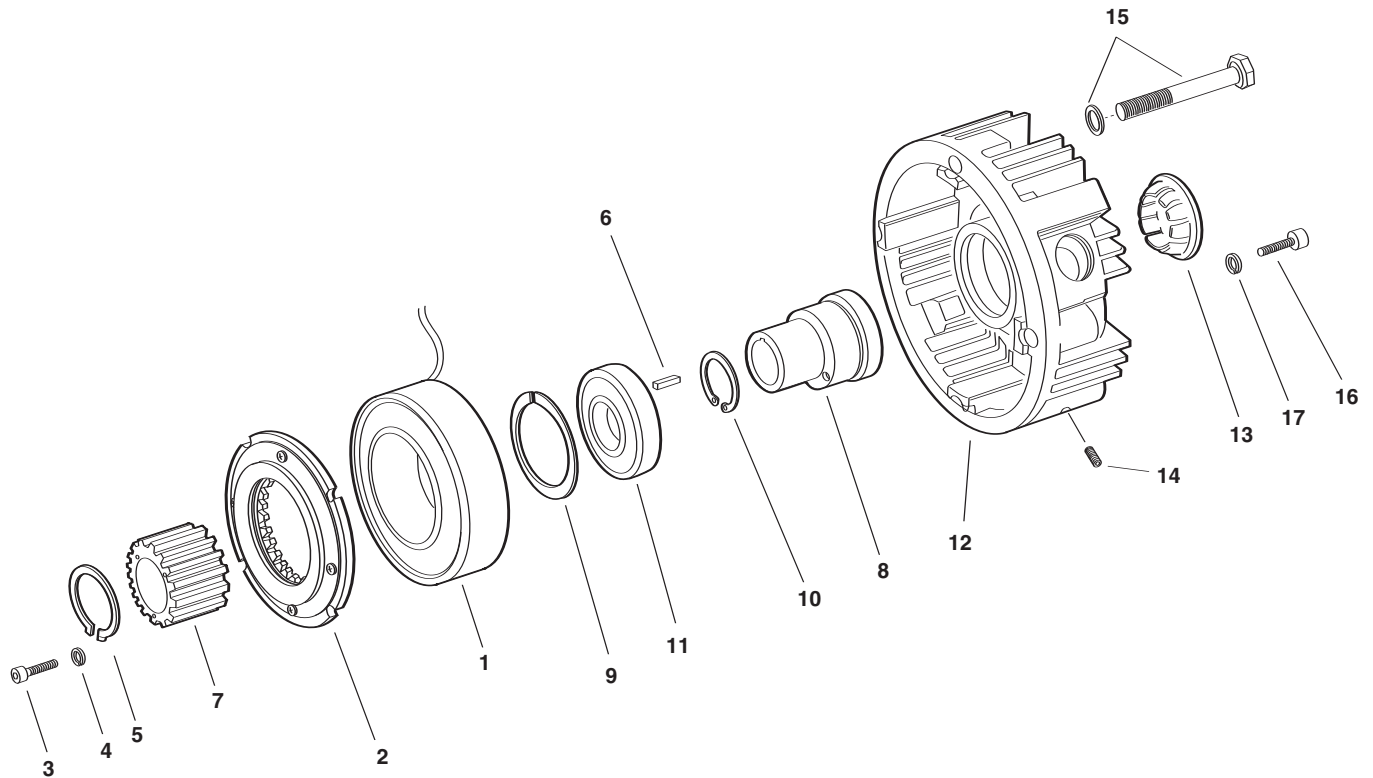

Component Parts

Item	Description	EM-50		EM-100		EM-180		EM-210	
		Part No.	Qty.	Part No.	Qty.	Part No.	Qty.	Part No.	Qty.
1 & 2	Magnet and Armature (sold only in matched pairs)* 24 volt 90 volt	5370-6 5370-1	1	5370-8 5370-2	1	5370-8 5370-2	1	5371-3 5371-1	1
3	Capscrew							797-0081	6
4	Lockwasher							950-0372	6
5	Retaining Ring	748-0445	1						
6	Key	590-0043	1	590-0084	1	590-0084	1		
7	Splined Hub	540-1638	1	540-1677	1	540-1642	1	540-0741	1
8	Hub	5370-541-002	1	5370-541-004	1	5370-541-003	1	5371-541-001	1
9	Retaining Ring	748-0013	2	748-0101	1	748-0101	1	748-0112	1
10	Retaining Ring			748-0676	1	748-0676	1		
11	Bearing	166-0149	1	166-0101	1	166-0101	1	166-142	1
12	Housing	535-0136	1	535-0150	1	535-0150	1	535-0149	1
13	Plug	680-0028	1	680-0028	1	680-0028	1	680-0027	1
14	Setscrew	797-0471	4	797-0471	4	797-0471	4	797-0471	4
15	Mounting Accessory	5370-101-017	1	5370-101-017	1	5370-101-023	1	5371-101-007	1
16	Magnet mounting Screw			797-1214	2	797-1214	2	797-0083	2
17	Lockwasher							950-0372	2

Refer to Service Manual P-213.

*Magnets and armatures sold only in pre-burnished sets to assure maximum torque is available upon installation.

Service Parts

EM-20FBC Clutch/Brake Module

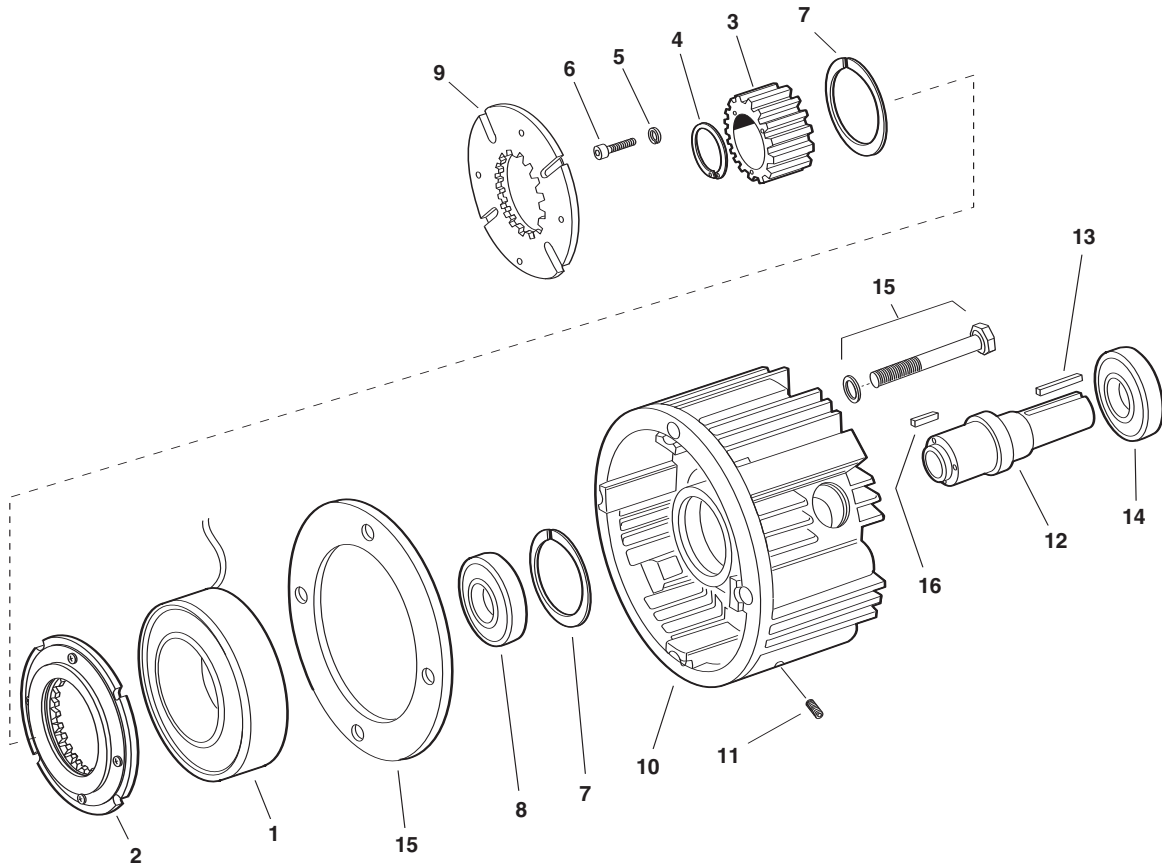

Component Parts

Item	Description	EM-50		EM-180		EM-210	
		Part No.	Qty.	Part No.	Qty.	Part No.	Qty.
1 & 2	Magnet and Armature (sold only in matched pairs)* 24 volt 90 volt	5370-6 5370-1	1	5370-8 5370-2	1	5371-3 5371-1	1
3	Armature Hub	540-1640	1	540-1644	1	540-0835	1
4	Retaining Ring	758-0445	1	748-0676	1	748-0112	1
5	Lockwasher					950-0372	6
6	Capscrow					797-0081	6
7	Retaining Ring	748-0113	2	748-0101	1		
8	Bearing	166-0149	1	166-0101	1	166-0142	1
9	Armature	5370-111-011	1	5370-111-013	1	5371-111-005	1
10	Housing	535-0130	1	535-0145	1	535-0144	1
11	Setscrew	797-0471	4	797-0471	4	797-0471	4
12	Shaft	798-0045	1	798-0086	1	798-0050	1
13	Key	590-0029	1	590-0029	1	590-0019	1
14	Bearing	166-0155	1	166-0143	1	166-0144	1
15	Mounting Accessory	5370-101-033	1	5370-101-034	1	5371-101-018	1
16	Key	590-0043	1	590-0084	1		
17	Capscrow			797-1214	2	797-0083	2
18	Lockwasher					950-0372	2

Refer to Service Manual P-213.

*Magnets and armatures sold only in pre-burnished sets to assure maximum torque is available upon installation.

Service Parts