

Wrap Springs Product Line

CB Series



SCB Series



WSC Series



Clutch/Brake Package

Each CB Series unit is a completely self-contained, packaged clutch/brake assembly designed to start and stop a load rapidly and accurately without any cumulative error. In fact, at speeds up to 1800 RPM, loads are started and stopped within $\pm 1/2^\circ$ per revolution. CB Series units are solenoid actuated with standard models available in 12, 24, or 90 VDC as well as 115 VAC configurations.

Accurate

Start and stop positioning can be maintained within $\pm 1/2^\circ$ at speeds up to 1800 RPM. The stop point is adjustable by using the adjustable control collar.

Self-Contained

Each CB Series unit is completely self-contained. Assembly and testing before shipment ensure reliable and trouble-free operation.

Interchangeability

The CB Series is completely interchangeable with other comparable clutch/brake packages.

Features

- CW or CCW rotation
- Anti-back: anti-overrun feature
- 12, 24 or 90 VDC, 115 VAC operation
- 1, 2 or 4 stop collars standard; special stop collars also available (up to 24 stops)
- Adjustable stop collar
- Six standard sizes
- Torque ratings from 25 lb.in. to 2500 lb.in.

Long Life Clutch/Brake

The Super CB Series is a high performance version of the standard CB Series, providing up to five times the life. The SCB Series is recommended for heavy-duty applications requiring maximum torque, high cycle rates and minimum maintenance. Like the CB Series, each Super CB Series unit is a complete, factory-assembled package, ready for installation.

Features

- Heavy duty design
- High cycle rate performance
- Long life - up to five times that of a standard CB model
- Three standard models
- Torque ratings up to 2500 lb.in.
- CW or CCW rotation
- Anti-back: anti-overrun feature
- 12, 24, 90 VDC or 115 VAC operation
- 1, 2 or 4 stop collars standard; special stop collars also available (up to 24 stops)
- Adjustable stop collars

Wrap Spring Clutches

WSC Series clutches are simple, mechanically actuated devices providing high torque in a compact design. Specific models are available for use as an overrunning/one-way clutch (Model O), as a start/coast-to-stop clutch (Model SS), or as a single revolution clutch (Model S).

Overrunning/One-Way (Model O)

This clutch continually drives the load. The load is allowed to overrun the input, should its speed exceed input speed. In the reverse direction the unit acts as a one-way clutch, preventing the load from backing up.

Start/Coast-To-Stop (Model SS)

The start/stop clutch is engaged until the collar that contains the spring tang is disengaged. Once it is stopped, the load is disengaged and coasts to a stop.

Start/Stop – Single Revolution (Model S)

Attaching one end of the spring to the output hub results in a single revolution clutch. The load is stopped through the spring to the collar. Precise non-cumulative error single revolution cycling is achieved. Braking torque equals 10% of the maximum torque rating.

Features

- Five standard sizes
- Torque ratings from 25 lb.in. to 2500 lb.in.
- Hub or shaft input
- Multiple stop collars
- Over-travel stop
- Anti-overrun
- Adjustable stop feature

Principle of Operation

The three basic components of the wrap spring clutch are the input hub, output hub, and spring. The inside diameter of the spring is slightly smaller than the outside diameter of the two hubs. Rotation at the input hub in the direction of the arrow engages the spring and positively locks the two hubs together. Adding a control tang enables the spring to be disengaged, allowing the input hub to overrun.

Combination Clutch/Brake

The control tangs are used to hold open the clutch or brake spring, which are wrapped in opposite directions. When the clutch and brake control tangs rotate with the input hub, the input hub and output shaft are engaged by the clutch spring. When the stop collar locks the control tang of the brake spring, it wraps down engaging the output shaft to the brake hub. The clutch spring unwraps at the same time, allowing the input hub to freely rotate.

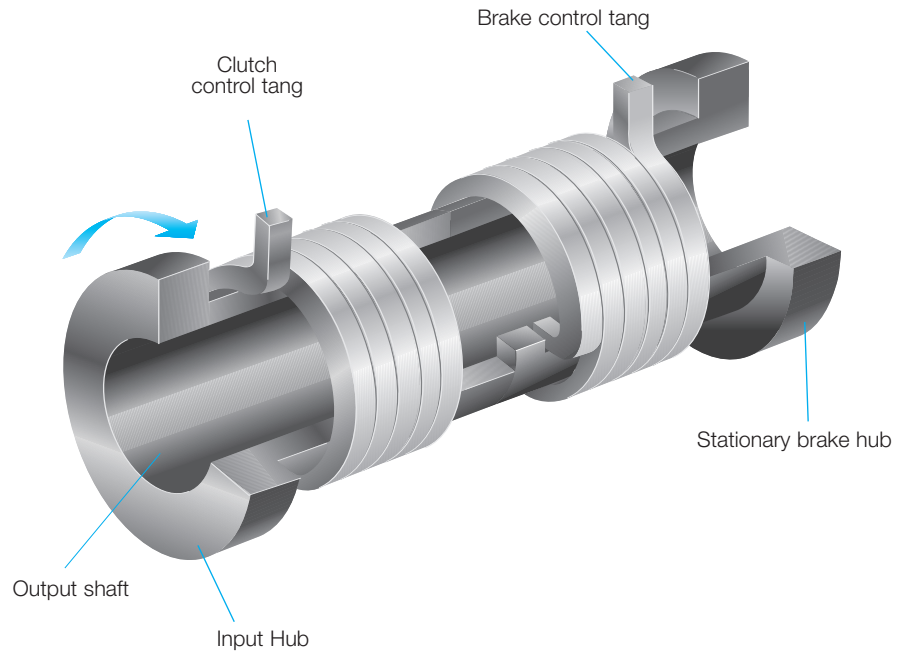

Design Configurations

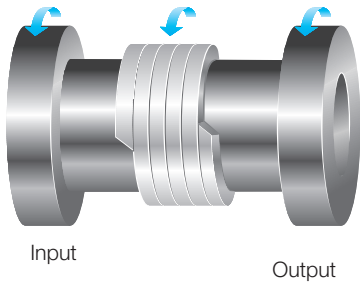

Input

Output

Model O

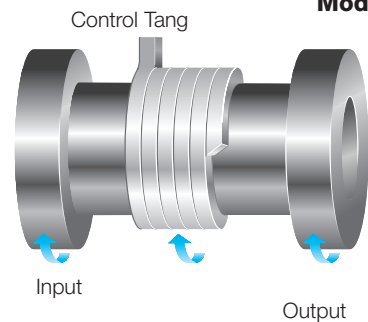

Control Tang

Input

Output

Model SS

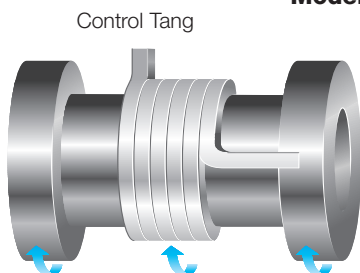

Control Tang

Input

Output

Model S

Overrunning (One Way Clutch)

When the input is rotated in the direction shown, the spring wraps down and engages the input to the output hub. When the input hub is stopped or reversed, the spring unwraps, allowing the output hub to overrun. These clutches can also be used for backstopping and indexing. In the backstopping mode, either the input or output hub is attached to a fixed member and the other hub on a rotating part. Rotation is permitted in one direction, but locked in reverse rotation. Indexing provides an accurate and smooth intermittent rotary output from reciprocating input in variable angular increments.

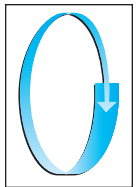

Start/Coast-To-Stop Clutch (Random Positioning)

In this mode, the control tang rotates with the input hub, thus the clutch is engaged. When the stop collar locks the control tang, the spring unwraps, allowing the output hub to coast while the input hub continues to run.

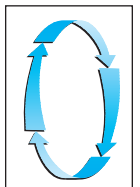

Start/Stop – Single Revolution Clutch

In this mode another control tang is added to the spring and fixed to the output hub. When the stop collar engages the control tang, the output hub will not overrun. Remember only a maximum of 10% of the load will be stopped with the single revolution clutch.

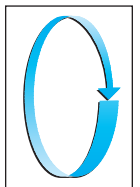

Application Examples

Application Examples

The features of wrap spring clutches and brakes; accuracy, repeatability, high torque-to-size ratio, low power consumption and long life make them an ideal solution for a wide range of motion control applications. Basic functions include overrunning, single revolution, random positioning start-stop, high cycle rate rapid start-stops and accurate, repeatable positioning.

Typical Applications

- Conveyors
- Rotary indexing tables
- Packaging equipment
- Bagging machinery
- Collators
- Cut-off machines
- Vending machines
- Copiers
- Food processing equipment
- Paper feeds
- Folders
- Material handling equipment
- Riveters, staplers and stitching machines
- Sorters
- Punch presses
- Textile machines
- Film and wire processing

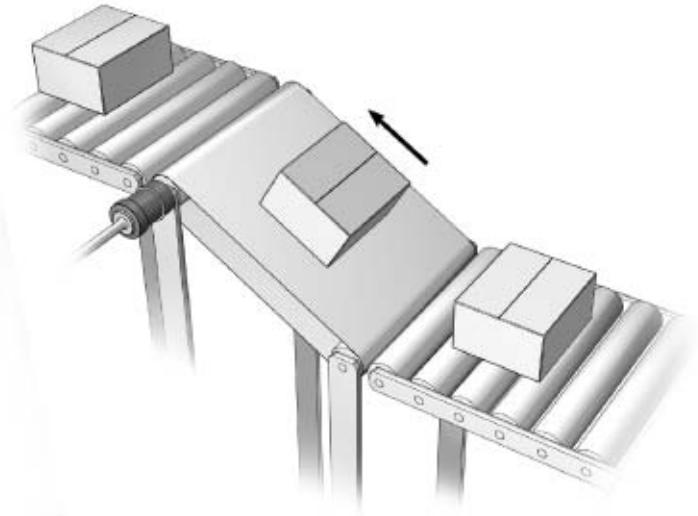

Incline Conveyor

The **WSC Model O** mechanical wrap spring clutch provides maintenance free anti-backup protection for this incline conveyor. While the conveyor is running, the wrap spring is in overrunning mode, allowing the clutch's output to freewheel. When the conveyor drive power is removed, either intentionally or unintentionally, the spring holds the hub stationary and will prevent the conveyor and its load from back-driving.

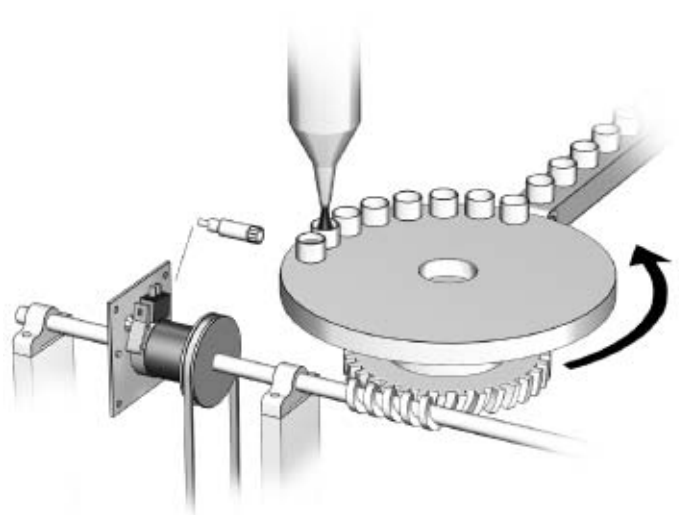

Indexing Rotary Table

Each time the power supply provides a pulse to the solenoid of the Standard CB wrap spring clutch/brake, the table indexes one position for filling, labeling, sorting, staging or inspecting products. **CB, Super CB or WSC Model S** (with customer supplied actuator) units may each be used to perform the indexing function. Please note that while the graphic shows open gearing, a standard enclosed gearbox will work just as effectively.

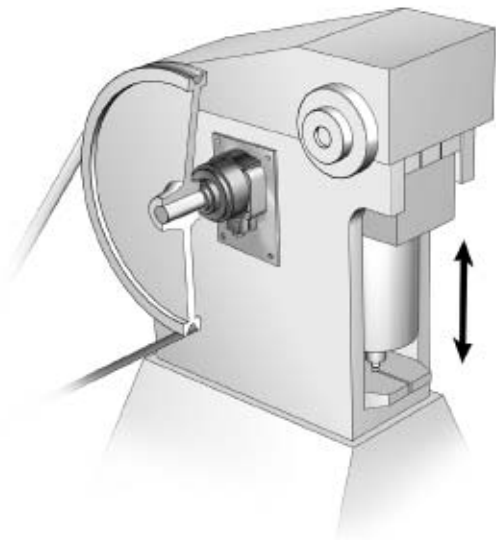

Industrial Stitchers and Staplers

The motor drives a large flywheel and a cam connected to the stitcher head. The **CB** or **Super CB** wrap spring clutch/brake provides one complete cycle, always stopping at the same precise position in time for the next cycle. Warner Electric's **CB** and **Super CB** units never require any adjustment or lubrication, and provide non-cumulative error for cycle-to-cycle accuracy and consistency.

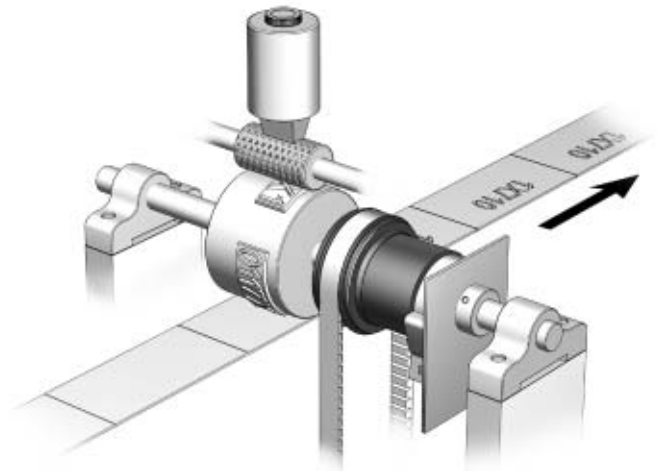

Print Head

In this printing application, a photoelectric sensor detects the registration mark on the web and signals the **CB** or **Super CB** clutch/brake to cycle. Each cycle drives the print wheel in registration with the continuously moving web material. Warner Electric wrap spring clutch/brakes provide start and stop positioning within a $\pm 1/2^\circ$ per revolution (non-cumulative), making them an excellent solution for applications requiring highly accurate, consistent performance.

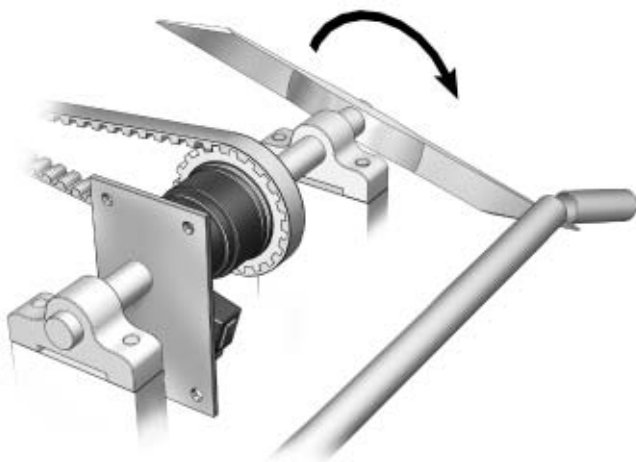

Cut-Off Knife

As tubing material is fed, a sensor determines when the appropriate length has been reached, and signals the clutch/brake to cycle, driving the knife to cut the tubing to the correct length. This application shows a standard option two-stop collar, which indexes 180° per sensor input, making two cuts per one complete 360° revolution. The **CB** or **Super CB** clutch/brake provides error free indexing, making the reaction time for the knife consistent from cycle-to-cycle.

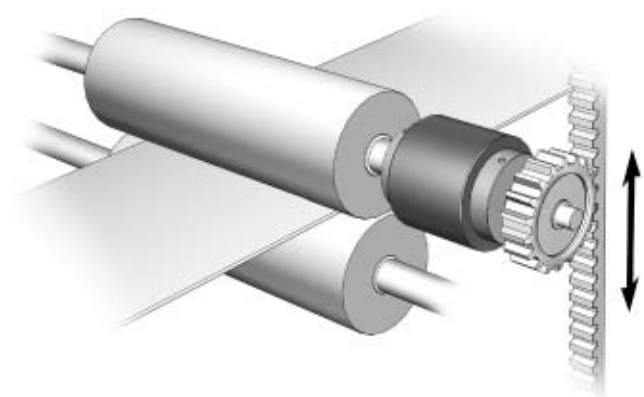

Rack and Pinion Indexing

The unidirectional **WSC Model O** operates as an indexing drive for this application. As the rack moves upward, the wrap spring clutch drives, providing torque to the in-feed rolls. When the rack moves downward, the wrap spring clutch freewheels, transmitting no torque to the rolls. Since the cam, pinion gear and rolls are all constant diameters, coupled with the accuracy of the **WSC**, the amount fed each cycle remains constant and consistent.

Selection

For Product Selection Follow 3 Easy Steps

Wrap spring clutches and brakes are pre-packaged, pre-assembled units which are as easy to select as they are to install. The simple three step selection process includes:

Step 1 Determine the clutch or brake function

Step 2 Determine size

Step 3 Verify design considerations

This selection process is based on the assumption that the diameter of the shaft at the clutch or clutch/brake location has been designed through good machine design practice. For most applications, this process will determine the correct size product. When the performance requirements of a given application are

marginally within the capabilities of a specific product, consider using the next larger size. In instances where required load/speed performance data is known and unit size is uncertain, use the technical selection process starting on page 28 which will help you review the necessary aspects of your application.



Step 1 Determine clutch or brake function

Wrap spring clutches and brakes can perform three control functions—overrunning, start/coast-to-stop, and single revolution. Determine the function which will provide the best control for your application. Using the chart below, select the series which best fits your application requirements.

Step 2 Determine size

To select the correct size unit, determine the maximum RPM at which the clutch or brake will be operated and the shaft diameter on which the wrap spring unit will be mounted. A wrap spring clutch engages almost instantly, and, since spring wrap increases with load, the unit must be sized carefully to insure that it is correct for the application. If there is any uncertainty regarding the correct unit size, we recommend using the technical selection process starting on page 32. To select the correct wrap spring unit, locate the corresponding speed and shaft diameter points on the appropriate chart on page 7. For applications requiring speed or diameter values higher than those illustrated, please contact your local Warner Electric Distributor, your Market Representative, or Warner Electric Technical Support at (800) 825-9050.

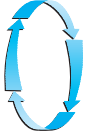
Selection by Function

Function	Performance	Wrap Spring Product	Max. Torque		Max. RPM	Actuation Method
			Starting lb. in. (N-m)	Stopping lb. in. (N-m)		
 <p>Overrunning</p>	An overrunning clutch will transmit torque in one direction only when the input hub is stopped or reversed. Consequently, the load is disengaged and free to rotate or overrun.	WSC Series Model O	2,500 (282.5)	N/A	1,800	Reverse input rotation
Engaged in one direction only						
 <p>Start/Coast-To-Stop</p>	A start/coast-to-stop clutch will engage and disengage a load either by mechanical or electrical actuation. Start/coast-to-stop clutches provide a random stop position for the load.	WSC Series Model SS	2,500 (282.5)	0	1,800	Mechanical
Random Positioning						
 <p>Single Revolution</p>	A single revolution clutch or clutch/brake will accurately position a load with no cumulative error for each single revolution cycle. Multiple stop collars with up to 24 stops (per revolution) provide fractional revolution capability.	WSC Series Model S	2,500 (282.5)	250 (282.5)	1,800	Mechanical
Accurate positioning for single or multiple stops		Super CB	2,500 (282.5)	2,500 (282.5)	750	AC or DC Solenoid
		Standard CB	2,500 (282.5)	2,500 (282.5)	1,800	AC or DC Solenoid

Step 3

Verify design function considerations

Once the appropriate series and model size have been determined, review the design considerations. A complete checklist of these and other options available are detailed in the How to Order section for each series.

Design Considerations

All Models

- CW or CCW rotation
- Single or multiple stop collar
- Bore size

Super CB and CB Series

- AC or DC solenoid
- CB-5, CB-6 and CB-8 sizes available in the long life, Super CB Series. See pages 19–23 for specific details.

WSC Series

- Hub input/shaft output or shaft input/hub output
- Overrunning Model O, start/coast-to-stop Model SS or single revolution Model S

Selection Charts – RPM vs. Shaft Diameter

Super CB and Standard CB Series

Clutch Size	Bore Size	200	300	400	500	600	700	800	900	1000	1100	1200	1300	1400	1500	1600	1700	1800
2	1/4																	
4	3/8																	
5	1/2																	
6	3/4																	
6	1																	
8	1*																	
8	1 1/4																	
8	1 3/8*																	
8	1 1/2																	

* Special Order RPM

WSC Series

Clutch Size	Bore Size	200	300	400	500	600	700	800	900	1000	1100	1200	1300	1400	1500	1600	1700	1800
2	1/4																	
4	3/8																	
5	1/2																	
6	3/4																	
6	1																	
8	1																	
8	1 1/4																	
8	1 3/8																	
8	1 1/2																	

RPM