V-BELT ADJUSTABLE PITCH SHEAVES



FHP



JVS



5VS-8VS



SVS



LIGHT-DUTY (FHP) ADJUSTABLE SHEAVE DIMENSIONS

The one and two groove adjustable sheaves are machined from annealed cast iron and are designed for 3L, 4L (A), 5L (B) or 5V V-Belts. The datum diameter of the sheaves is adjusted by loosening the setscrews in the hubs and turning the threaded flange to the desired setting and then the setscrews are retightened. The sheaves will give 30% change in datum diameter.



One Groove



Two Groove

VP SERIES

Pitch Diameter and Turns

One Groove

Product Number	3L or O				4L or A				5L or B				5V			
	Max. Pitch	Turns Open	Min. Pitch	Turns Open	Max. Pitch	Turns Open	Min. Pitch	Turns Open	Max. Pitch	Turns Open	Min. Pitch	Turns Open	Max. Pitch	Turns Open	Min. Pitch	Turns Open
1VP25	2.46	0	1.73	3.5	na	na	na	na	na	na	na	na	na	na	na	na
1VP30	2.71	0	1.84	4	na	na	na	na	na	na	na	na	na	na	na	na
1VP34	2.92	0	2.06	4	3.13	1.5	2.41	5	3.19	3.5	2.77	5.5	na	na	na	na
1VP40	3.22	0	2.27	4.5	3.75	0	2.57	6	3.81	2	2.98	6	na	na	na	na
1VP44	3.62	0	2.67	4.5	4.15	0	2.97	6	4.21	2	3.38	6	na	na	na	na
1VP50	4.22	0	3.27	4.5	4.75	0	3.57	6	4.81	2	3.98	6	na	na	na	na
1VP56	4.82	0	3.87	4.5	5.35	0	4.17	6	5.41	2	4.58	6	na	na	na	na
1VP60	na	na	na	na	5.48	0	4.30	6	5.92	0	4.74	6	na	na	na	na
1VP62	5.42	0	4.47	4.5	5.95	0	4.77	6	6.01	2	5.21	6	6.36	2	5.56	6
1VP65	na	na	na	na	5.98	0	4.80	6	6.45	0	5.24	6	6.39	0	5.18	6
1VP68	6.02	0	5.07	4.5	6.55	0	5.37	6	6.61	2	5.81	6	6.96	2	6.16	6
1VP71	na	na	na	na	6.58	0	5.40	6	7.05	0	5.84	6	6.99	0	5.78	6
1VP75	na	na	na	na	6.98	0	5.95	6	7.45	0	6.24	6	7.39	0	6.18	6

Two Groove

Product Number	3L or O				4L or A				5L or B				5V			
	Max. Pitch	Turns Open	Min. Pitch	Turns Open	Max. Pitch	Turns Open	Min. Pitch	Turns Open	Max. Pitch	Turns Open	Min. Pitch	Turns Open	Max. Pitch	Turns Open	Min. Pitch	Turns Open
2VP36	2.82	0	2.50	1.5	3.35	0	2.88	2.5	3.41	2	3.13	3.5	na	na	na	na
2VP42	3.42	0	2.47	4.5	3.95	0	2.81	5.5	4.01	2	3.18	6	na	na	na	na
2VP50	4.22	0	3.27	4.5	4.75	0	3.57	6	4.81	2	3.98	6	na	na	na	na
2VP56	4.82	0	3.87	4.5	5.35	0	4.17	6	5.41	2	4.58	6	na	na	na	na
2VP60	na	0	na	na	5.48	0	4.30	6	5.95	0	4.74	6	na	na	na	na
2VP62	5.42	0	4.47	4.5	5.95	0	4.77	6	6.01	2	5.21	6	6.36	2	5.56	6
2VP65	na	0	na	na	5.98	0	4.75	6	6.45	0	5.24	6	6.39	0	5.18	6
2VP68	6.02	0	5.07	4.5	6.55	0	5.37	6	6.61	2	5.81	6	6.96	2	6.16	6
2VP71	na	0	na	na	6.58	0	5.40	6	7.05	0	5.84	6	6.99	0	5.78	6
2VP75	na	0	na	na	6.98	0	5.80	6	7.45	0	6.24	6	7.39	0	6.18	6

LIGHT-DUTY (FHP) ADJUSTABLE SHEAVE DIMENSIONS



VP SERIES

One Groove

Product Number	Outside Diameter	Overall Length	Weight Lbs.	Stock Bores									Max Bore	
				1/2	5/8	3/4	7/8	1	1 1/8	1 1/4	1 3/8	1 5/8		
1VP25	2.58	1.59	0.7	x	x	x								3/4
1VP30	2.83	1.66	1.1	x	x	x								3/4
1VP34	3.15	1.88	1.4	x	x	x	x	x	x					1 1/8
1VP40	3.75	1.88	1.9	x	x	x	x	x	x					1 1/8
1VP44	4.15	1.88	2.4	x	x	x	x	x	x					1 1/8
1VP50	4.75	2.00	3.6	x	x	x	x	x	x					1 1/8
1VP56	5.35	1.88	4.4	x	x	x	x	x	x					1 1/8
1VP60	6.00	1.66	6.5		x	x	x		x		x	x		1 5/8
1VP62	5.95	1.91	6.1		x	x	x	x	x	x	x			1 5/8
1VP65	6.50	1.66	6.8			x	x		x		x	x		1 5/8
1VP68	6.55	1.91	7.3		x	x	x	x	x	x	x			1 5/8
1VP71	7.10	1.66	8.5			x	x		x		x	x		1 5/8
1VP75	7.50	1.66	9.2			x	x		x		x	x		1 5/8

Two Groove

Product Number	Outside Diameter	Overall Length	Weight Lbs.	Stock Bores									Max Bore	
				1/2	5/8	3/4	7/8	1	1 1/8	1 1/4	1 3/8	1 5/8		
2VP36	3.35	3	3.4	x	x	x	x	x	x					1 1/8
2VP42	3.95	3	4.4		x	x	x	x	x					1 1/8
2VP50	4.75	3	6.3		x	x	x	x	x					1 1/8
2VP56	5.35	3	7.8		x	x	x	x	x		x	x		1 5/8
2VP60	6.00	3.25	10.6			x	x	x	x		x	x		1 5/8
2VP62	5.95	3	10			x	x	x	x	x	x			1 5/8
2VP65	6.50	3.25	12.3			x	x		x		x	x		1 5/8
2VP68	6.55	3	11.7			x	x	x	x	x	x	x		1 5/8
2VP71	7.10	3.25	14.6			x	x		x		x	x		1 5/8
2VP75	7.50	3.25	16.5			x	x		x		x	x		1 5/8

Product No. Example: 1VP40 Sheave with 5/8" Bore = 1VP4058 (Product No.)

Bore	Keyseat
1/2	NONE
5/8 to 7/8	3/16 x 3/32
1 to 1-1/4	1/4 x 1/8
1-5/16 x 1-3/8	5/16 x 5/32
1-7/16 x 1-5/8	3/8 x 3/16

FEATURES

- For A-B or 5V Belts
- Up to 40 HP @ 1750 rpm
- Needs No Lubrication
- Won't Freeze or Stick
- Wider Speed Range

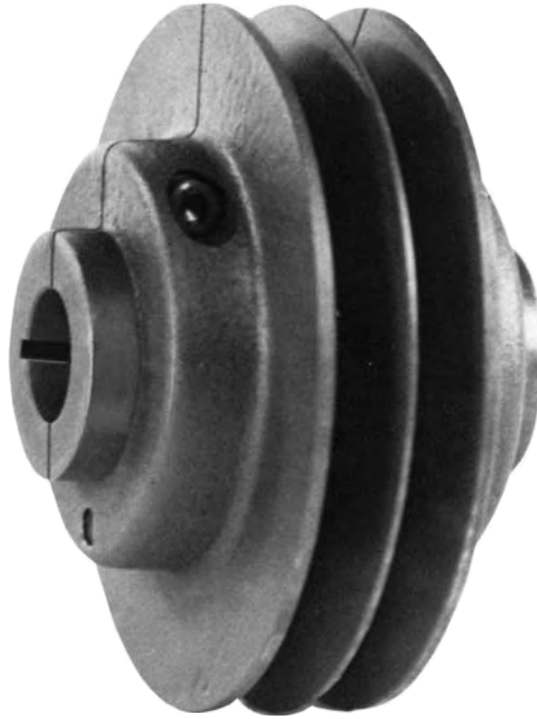

Wood's JVS stationary control, adjustable speed sheaves offer several significant advantages. This sheave is available in 6 sizes from 5.118 inches (130 mm) to 9.055 inches (230 mm) in diameter. It uses Classical A and B belts and Narrow 5V belts. Capacities range up to 40 hp at 1750 rpm. Its speed is infinitely variable, and because one screw controls both moveable flanges, accurate groove spacing is assured at all times. It uses a clamping collar design with no threads on either the sleeve or the flanges, so there is no chance of fretting corrosion and sticking. No lubrication is needed.

JVS ADJUSTABLE SPEED SHEAVES



DIMENSIONS

Product No.	Stock Bores	Max. Bore
JVS1302	1-1/8, 1-3/8	1.3750
JVS1502	1-1/8, 1-3/8, 1-5/8	1.6875
JVS1702	1-1/8, 1-3/8, 1-5/8	1.6875
JVS1902	1-3/8, 1-5/8, 1-7/8	2.4375
JVS2102	1-3/8, 1-5/8, 1-7/8, 2-1/8	2.4375
JVS2302	1-3/8, 1-5/8, 1-7/8, 2-1/8	2.4375

Product No. Example:

JVS1302 with 1-3/8" Bore = JVS1302138 (Product No.)

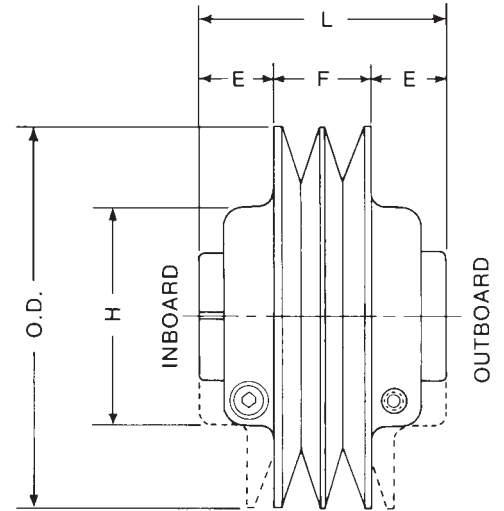

Product No.	PITCH DIA. RANGE			O.D.	DIMENSIONS					WT. (Lbs.)	
	A Belts	B Belts	5V Belts		L	F		E			H
						Min.	Max.	Min.	Max.		
JVS1302	3.80 - 4.62	4.21 - 5.21	...	5.12	3.77	1.73	2.27	.75	1.02	3.15	7.5
JVS1502	4.35 - 5.45	4.61 - 6.01	4.35 - 5.91 †	5.90	4.13	1.73	2.59	.77	1.20	3.62	11.5
JVS1702	5.05 - 6.15	5.31 - 6.71	5.14 - 6.69 †	6.69	4.13	1.73	2.59	.77	1.20	3.62	12.5
JVS1902	5.86 - 6.95	6.11 - 7.51	5.92 - 7.48	7.48	4.13	1.73	2.59	.77	1.20	5.12	20.5
JVS2102	6.65 - 7.75	6.91 - 8.31	6.71 - 8.27	8.27	4.13	1.73	2.59	.77	1.20	5.12	22.5
JVS2302	7.45 - 8.55	7.71 - 9.11	7.50 - 9.05	9.06	4.13	1.73	2.59	.77	1.20	5.12	26.0

Note: JVS sheaves use standard 2 Groove "B" or "5V" sheaves as companions.

† Recommended for use with Narrow Cog Belts only.

Note: One turn of the adjusting screw varies the pitch .2". Maximum to minimum adjustment requires seven turns.



5VS AND 8VS ULTRA-V ADJUSTABLE SHEAVE FEATURES

- For the 5V & 8V Narrow Belt
- More hp per inch Face Width
- Capacities to 500 hp @ 1750 rpm
- Interchangeable Bushings
- Needs No Lubrication
- Won't Freeze or Stick



The narrow stationary control adjustable speed sheaves feature a design which uses a tapered bushing to lock all moveable parts and clamp the sheave to the shaft, thus eliminating fretting corrosion and minimizing unbalance. The 5VS sheaves are available in five basic sizes—5VS240, 5VS265, 5VS290, 5VS315 and 5VS355. The 5VS240 and 5VS265 sheaves are available with 2 through 6 grooves; and the 5VS290 through 5VS355 with 2 through 8 grooves. The 8VS sheaves are available in two basic sizes—8VS355 and 8VS-405, which are available with 4 through 8 grooves.

These sheaves are fitted with a split interchangeable bushing which is carried in stock with the popular bores. See chart on following pages for bores available from stock.

Companion sheave selection depends upon the number of grooves in the 5VS sheave.

5VS SHEAVE	USE COMPANION
2 Groove	2 Groove – Stock 5V
3 Groove	5 Groove – Stock 5V
4 Groove	7 Groove – Stock 5V
5 Groove	9 Groove – Stock 5V
6 Groove	Stock 6 Groove Wide Space Companion
8 Groove	MTO 8 Groove Wide Spaced Companion

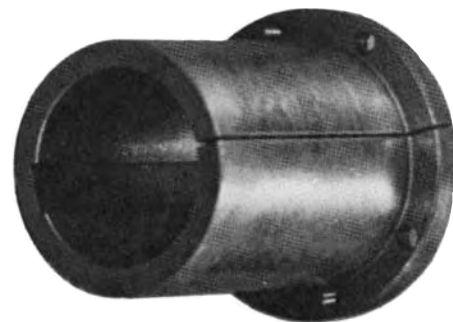

NOTE: 8VS Sheaves use MTO 8V Wide Groove Companions

5VS ADJUSTABLE SHEAVES

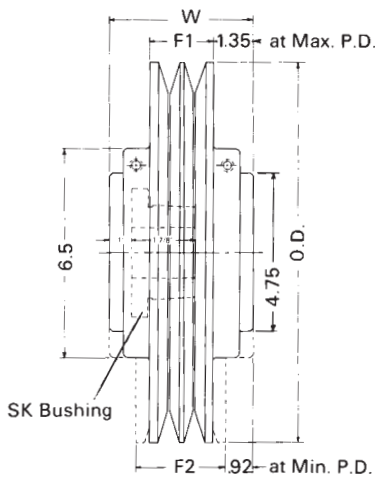

2 Groove Only
Max. to min. pitch 7-1/2 turns.
Each turn varies pitch .18".

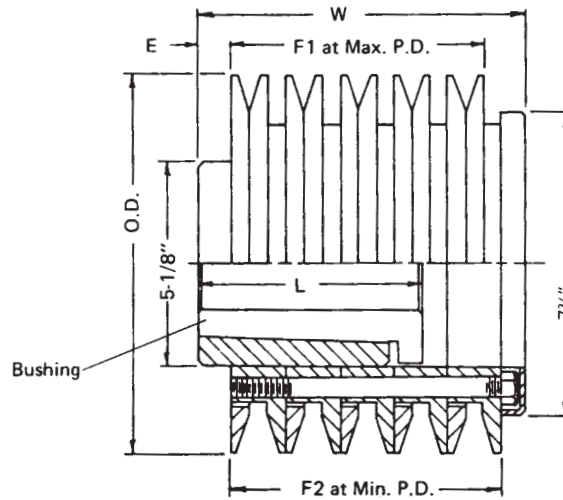

3 Thru 8 Grooves
Max. to min. pitch 6 turns.
Each turn varies pitch .25".

5VS SHEAVES

2, 3, 4, 5, 6 & 8 GROOVES

Product No.	P.D.		O.D.	Bushing Product No	DIMENSIONS					WT. Lbs.
	Min.	Max.			F1	F2	W	E	L	
5VS2402	8.17	9.54	9.56	SK	1.89	2.75	4.59	34
5VS2403	8.17	9.54	9.56	5VSSB	3.70	4.13	5.30	.43	5.27	52
5VS2404	8.17	9.54	9.56	5VSSB	5.07	5.50	6.67	.43	5.27	64
5VS2405	8.17	9.54	9.56	5VSSB	6.45	6.88	8.05	.43	5.27	76
5VS2406	8.17	9.54	9.56	5VSLB	7.80	8.26	9.43	.43	8.46	100
5VS2652	9.16	10.54	10.56	SK	1.89	2.75	4.59	40
5VS2653	9.16	10.54	10.56	5VSSB	3.70	4.13	5.30	.43	5.27	62
5VS2654	9.16	10.54	10.56	5VSSB	5.07	5.50	6.67	.43	5.27	78
5VS2655	9.16	10.54	10.56	5VSSB	6.45	6.88	8.05	.43	5.27	92
5VS2656	9.16	10.54	10.56	5VSLB	7.80	8.26	9.43	.43	8.46	118
5VS2902	10.14	11.52	11.54	SK	1.89	2.75	4.59	46
5VS2903	10.14	11.52	11.54	5VSSB	3.70	4.13	5.30	.43	5.27	74
5VS2904	10.14	11.52	11.54	5VSSB	5.07	5.50	6.67	.43	5.27	92
5VS2905	10.14	11.52	11.54	5VSSB	6.45	6.88	8.05	.43	5.27	110
5VS2906	10.14	11.52	11.54	5VSLB	7.80	8.26	9.43	.43	8.46	140
5VS2908	10.14	11.52	11.54	5VSLB	10.56	11.00	12.18	.43	8.46	178
5VS3152	11.12	12.50	12.52	SK	1.89	2.75	4.59	52
5VS3153	11.12	12.50	12.52	5VSSB	3.70	4.13	5.30	.43	5.27	84
5VS3154	11.12	12.50	12.52	5VSSB	5.07	5.50	6.67	.43	5.27	106
5VS3155	11.12	12.50	12.52	5VSSB	6.45	6.88	8.05	.43	5.27	130
5VS3156	11.12	12.50	12.52	5VSLB	7.80	8.26	9.43	.43	8.46	162
5VS3158	11.12	12.50	12.52	5VSLB	10.56	11.00	12.18	.43	8.46	210
5VS3552	12.69	14.07	14.09	SK	1.89	2.75	4.59	52
5VS3553	12.69	14.07	14.09	5VSSB	3.70	4.13	5.30	.43	5.27	104
5VS3554	12.69	14.07	14.09	5VSSB	5.07	5.50	6.67	.43	5.27	133
5VS3555	12.69	14.07	14.09	5VSSB	6.45	6.88	8.05	.43	5.27	164
5VS3556	12.69	14.07	14.09	5VSLB	7.80	8.26	9.43	.43	8.46	202
5VS3558	12.69	14.07	14.09	5VSLB	10.56	11.00	12.18	.43	8.46	264

Note: All dimensions in the above tables are in inches.
Maximum speed of all 5VS sheaves is 1800 RPM.

BUSHING DIMENSIONS

Prod. No.	Stock Bores	Diameter	Length	Wt. (Lbs.)
5VSSB	1-7/8, 2-1/8, 2-3/8, 2-7/8, 3-3/8	5.10	5.27	11.5
5VSLB	2-3/8, 2-7/8, 3-3/8*	5.10	8.46*	9.0

* 3-3/8 Bore only; Length = 7.0

Product No. Example: 5VSSB Bushing with a 2-3/8" Bore = 5VSSB238 (Product No.)

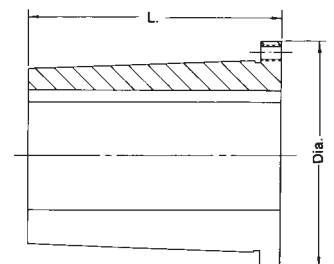

COMPANION SHEAVES FOR 5VS ADJUSTABLES

O.D. ◆	6 GROOVES (WIDE GROOVE SPACING)								8 GROOVES (WIDE GROOVE SPACING)*					
	Product No.	F = 7.88							F = 10.62					
		Bush.	Type	E	K	L	M	Wt.	Bush.	Type	E	K	L	M
8.0	E	A	3.38	4.25	2.62	4.62
8.5	E	A	3.38	4.25	2.62	4.62
9.0	F	A	2.38	3.38	3.62	4.62
9.25	F	A	2.38	3.38	3.62	4.62
9.75	F	A	2.38	3.38	3.62	4.62
10.3	5V1036W	F	A1	2-1/8	3-1/8	3-5/8	2-1/8	81.4	F	A	2.38	3.38	3.62	4.62
10.9	5V1096W	F	A1	2-1/8	3-1/8	3-5/8	2-1/8	89.2	J	A	2.5	3.68	4.5	3.62
11.3	5V1136W	F	A1	2-1/8	3-1/8	3-5/8	2-1/8	97.7	J	A	2.5	3.68	4.5	3.62
11.8	5V1186W	F	A1	2-1/8	3-1/8	3-5/8	2-1/8	103.9	J	A	2.5	3.68	4.5	3.62
12.5	5V1256W	F	A2	2-1/8	3-1/8	3-5/8	2-1/8	95.7	J	A	2.5	3.68	4.5	3.62
13.2	5V1326W	F	A2	2-1/8	3-1/8	3-5/8	2-1/8	102.3	J	A	2.5	3.68	4.5	3.62
14.0	5V1406W	F	A2	2-1/8	3-1/8	3-5/8	2-1/8	111.6	J	A	2.5	3.68	4.5	3.62
15.0	5V1506W	F	A3	2-1/8	3-1/8	3-5/8	2-1/8	110.9	M	A	2.5	3.68	4.5	3.62
16.0	5V1606W	F	A3	2-1/8	3-1/8	3-5/8	2-1/8	119.4	M	A	1.25	2.68	6.75	2.62
18.7	5V1876W	J	A3	3/4	1-15/16	4-1/2	2-5/8	160.8	M	A	1.25	2.68	6.75	2.62
20.0	M	A	1.25	2.68	6.75	2.62
21.2	5V2126W	J	A3	3/4	1-15/16	4-1/2	2-5/8	186.3	M	A	1.25	2.68	6.75	2.62
23.6	5V2366W	J	A3	3/4	1-15/16	4-1/2	2-5/8	218.3	M	A	1.25	2.68	6.75	2.62
25.0	M	A	1.25	2.68	6.75	2.62
28.0	5V2806W	J	A3	3/4	1-15/16	4-1/2	2-5/8	235.8	M	A	1.25	2.68	6.75	2.62
30.0	M	A	1.25	2.68	6.75	2.62
31.5	5V3156W	J	A3	3/4	1-15/16	4-1/2	2-5/8	272.4	M	A	1.25	2.68	6.75	2.62
35.5	N	A	0	1.75	8.12	2.5
37.5	5V3756W	J	A3	3/4	1-15/16	4-1/2	2-5/8	357.9	N	A	0	1.75	8.12	2.5
42.5	N	A	0	1.75	8.12	2.5
46.0	N	A	0	1.75	8.12	2.5
50.0	N	A	0	1.75	8.12	2.5
53.0	N	A	0	1.75	8.12	2.5
58.0	N	A	0	1.75	8.12	2.5
64.0	P	A	0	2.0	9.38	1.24
72.0	P	A	0	2.0	9.38	1.24

◆ P.D. = O.D.

* 8 Groove companions are MTO.

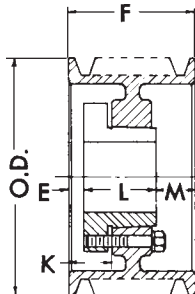

Type A

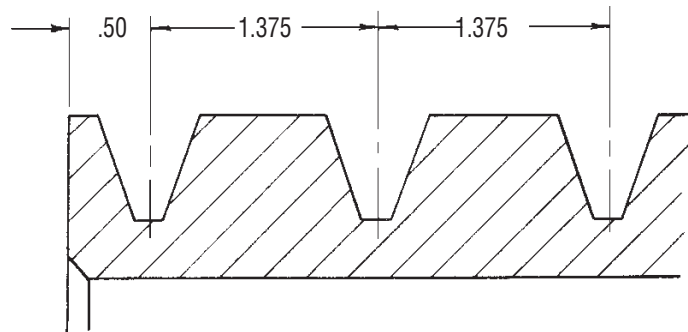

5V Wide-Groove Spaced Companions

8VS ADJUSTABLE SPEED SHEAVES



8VS SHEAVES

4, 5, 6 & 8 GROOVE

Max. to min. adjustment requires 8 turns. Pitch varies .25" per turn.

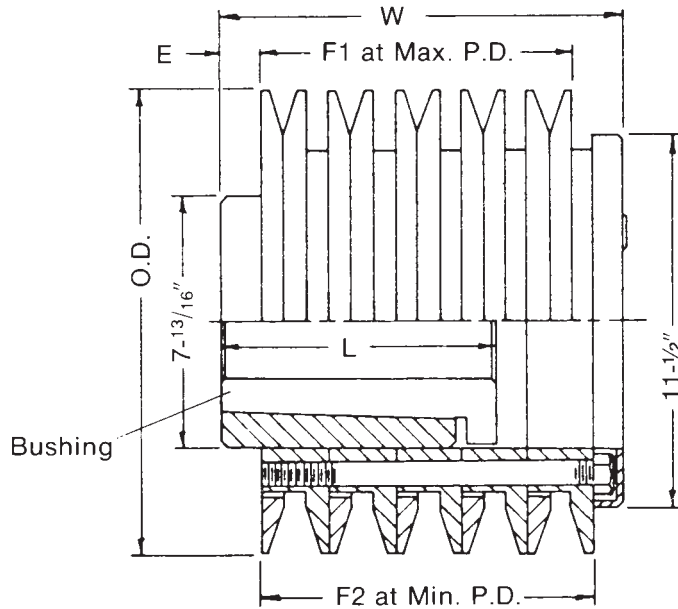

Product No.	P.D.		O.D.	Bushing	DIMENSIONS					WT.* Lbs.
	Min.	Max.			F1	F2	W	E	L	
8VS3554	12.20	14.18	14.17	8VS-SB	7.22	7.87	9.70	.65	9.33	187
8VS3555	12.20	14.18	14.17	8VS-SB	9.18	9.84	11.67	.65	9.33	220
8VS3556	12.20	14.18	14.17	8VS-SB	11.15	11.81	13.64	.65	9.33	256
8VS3558	12.20	14.18	14.17	8VS-LB	15.09	15.75	17.58	.65	12.36	340
8VS4054	14.18	16.14	16.14	8VS-SB	7.22	7.87	9.70	.65	9.33	215
8VS4055	14.18	16.14	16.14	8VS-SB	9.18	9.84	11.67	.65	9.33	250
8VS4056	14.18	16.14	16.14	8VS-SB	11.15	11.81	13.64	.65	9.33	290
8VS4058	14.18	16.14	16.14	8VS-LB	15.09	15.75	17.58	.65	12.36	388

* Weight does not include bushing.

Note: Max. RPM of 8VS-355 is 1800 and for 8VS-405 the max. RPM is 1500.

BUSHING DIMENSIONS

Prod. No.	Stock Bores	Diameter	Length	Wt. (Lbs.)
8VSSB	3-3/8, 3-7/8	7.75	9.33	34.0
8VSLB	3-3/8, 3-7/8, 4-3/8	7.75	12.36	40.0

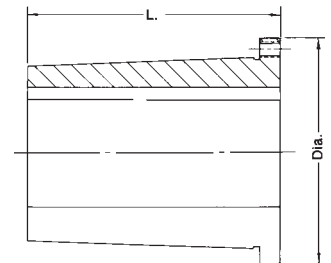

Product No. Example: 8VSLB Bushing with 3-7/8" Bore = 8VSLB378 (Product No.)

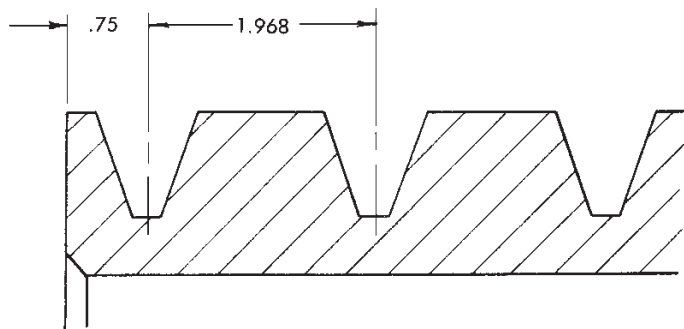



COMPANION SHEAVES FOR 8VS ADJUSTABLES

The companion sheaves for 8VS Adjustables have wide groove spacing and are made-to-order. The diameters can vary from those shown. However, the drives in the pre-engineered drive tables use the diameters listed here.

O.D. ◆	4 GROOVES (wide groove spacing)						5 GROOVES (wide groove spacing)						6 GROOVES (wide groove spacing)						8 GROOVES (wide groove spacing)					
	F = 7.40						F = 9.37						F = 11.34						F = 15.28					
	Bush.	Type	E	K	L	M	Bush.	Type	E	K	L	M	Bush.	Type	E	K	L	M	Bush.	Type	E	K	L	M
12.5	F	A	1.38	2.38	3.62	2.40	F	A	2.38	3.38	3.62	3.37	J	A	2.38	3.56	4.5	4.46	J	A	4.25	5.44	4.5	6.53
13.2	F	A	1.38	2.38	3.62	2.40	F	A	2.38	3.38	3.62	3.37	J	A	2.38	3.56	4.5	4.46	J	A	4.25	5.44	4.5	6.53
14.0	F	A	1.38	2.38	3.62	2.40	F	A	2.38	3.38	3.62	3.37	J	A	2.38	3.56	4.5	4.46	J	A	4.25	5.44	4.5	6.53
15.0	F	A	1.38	2.38	3.62	2.40	F	A	2.38	3.38	3.62	3.37	J	A	2.38	3.56	4.5	4.46	J	A	4.25	5.44	4.5	6.53
16.0	F	A	1.38	2.38	3.62	2.40	J	A	1.5	2.68	4.5	3.37	J	A	2.38	3.56	4.5	4.46	J	A	4.25	5.44	4.5	6.53
17.0	J	A	1.38	2.38	3.62	2.40	J	A	1.5	2.68	4.5	3.37	J	A	2.38	3.56	4.5	4.46	M	A	2.75	4.18	6.75	5.78
18.0	J	A	.94	2.12	4.5	1.96	J	A	1.5	2.68	4.5	3.37	J	A	2.38	3.56	4.5	4.46	M	A	2.75	4.18	6.75	5.78
19.0	J	A	.94	2.12	4.5	1.96	J	A	1.5	2.68	4.5	3.37	J	A	2.38	3.56	4.5	4.46	M	A	2.75	4.18	6.75	5.78
20.0	J	A	.94	2.12	4.5	1.96	J	A	1.5	2.68	4.5	3.37	M	A	.75	2.18	6.75	3.84	M	A	2.75	4.18	6.75	5.78
21.2	J	A	.94	2.12	4.5	1.96	J	A	1.5	2.68	4.5	3.37	M	A	.75	2.18	6.75	3.84	M	A	2.75	4.18	6.75	5.78
22.4	J	A	.94	2.12	4.5	1.96	M	A	.25	1.68	6.75	2.37	M	A	.75	2.18	6.75	3.84	M	A	2.75	4.18	6.75	5.78
23.6	J	A	.94	2.12	4.5	1.96	M	A	.25	1.68	6.75	2.37	M	A	.75	2.18	6.75	3.84	M	A	2.75	4.18	6.75	5.78
24.8	M	A	0	1.44	6.75	.65	M	A	.25	1.68	6.75	2.37	M	A	.75	2.18	6.75	3.84	M	A	2.75	4.18	6.75	5.78
28.0	M	A	0	1.44	6.75	.65	M	A	.25	1.68	6.75	2.37	M	A	.75	2.18	6.75	3.84	M	A	2.75	4.18	6.75	5.78
30.0	M	A	0	1.44	6.75	.65	M	A	.25	1.68	6.75	2.37	M	A	.75	2.18	6.75	3.84	N	A	2.75	4.5	8.12	4.41
35.5	M	A	0	1.44	6.75	.65	M	A	.25	1.68	6.75	2.37	M	A	.75	2.18	6.75	3.84	N	A	2.75	4.5	8.12	4.41
40.0	M	A	0	1.44	6.75	.65	M	A	.25	1.68	6.75	2.37	N	A	.75	2.5	8.12	2.47	N	A	2.75	4.5	8.12	4.41
42.5	M	A	0	1.44	6.75	.65	N	A	0	1.75	8.12	1.25	N	A	.75	2.5	8.12	2.47	N	A	2.75	4.5	8.12	4.41
44.5	M	A	0	1.44	6.75	.65	N	A	0	1.75	8.12	1.25	N	A	.75	2.5	8.12	2.47	P	A	2.75	4.5	8.12	4.41
48.0	M	A	0	1.44	6.75	.65	N	A	0	1.75	8.12	1.25	N	A	.75	2.5	8.12	2.47	P	A	2.0	4.0	9.38	3.90
53.0	N	B	.25	1.5	8.12	.47	N	A	0	1.75	8.12	1.25	N	A	.75	2.5	8.12	2.47	P	A	2.0	4.0	9.38	3.90
58.0	N	B	.25	1.5	8.12	.47	N	A	0	1.75	8.12	1.25	N	A	.75	2.5	8.12	2.47	P	A	2.0	4.0	9.38	3.90
63.0	N	B	.25	1.5	8.12	.47	N	A	0	1.75	8.12	1.25	P	A	0	2.0	9.38	1.96	P	A	2.0	4.0	9.38	3.90
71.0	N	B	.25	1.5	8.12	.47	P	A	0	2.0	9.37	0	P	A	0	2.0	9.38	1.96	P	A	2.0	4.0	9.38	3.90
78.0	N	B	.25	1.5	8.12	.47	P	A	0	2.0	9.37	0	P	A	0	2.0	9.38	1.96	P	A	2.0	4.0	9.38	3.90

◆ P.D. = O.D.

To order specify "8V" + O.D. + "X" + Number of Grooves + "W"

Example: 8V22.4 x 6W

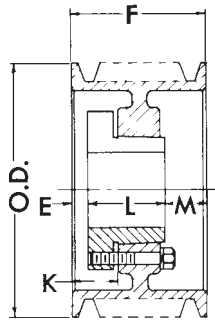

Type A

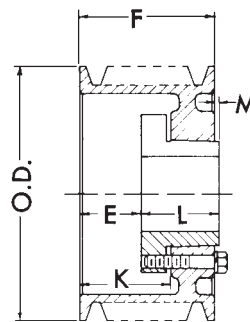

Type B

SVS ADJUSTABLE SHEAVE FEATURES



Wood's SVS standard v-belt adjustable speed sheave is a stationary control, multiple groove unit which provides accurate and infinite speed control within the datum diameter range of each sheave. There is no sticking or freezing. No lubrication is required. This sheave is easily installed, simply adjusted and accurately balanced to assure smooth operation and long drive life. It is of simple, highly efficient design and sturdy construction.



Type 1

U.S. Patent 2,753,723-2,907,597

All SVS sheaves are designed to provide easy datum diameter variation through a single adjusting screw. Positive locking collars clamp the adjustable flanges to the sleeve, thereby eliminating relative motion between sheave parts during operation. This prevents the fretting corrosion and freezing that could cause the unit to become non-adjustable.

SVS standard adjustable sheaves provide infinite speed variation within the range of the datum diameter variation. B Sheaves require 10 turns of the adjusting screw from max. to min., and C Sheaves require 12 turns. One turn changes the pitch dia. .14 (B) and .16 (C).

Wood's Type 1 for 2, 3 and 4 groove SVS sheaves are designed to operate with standard conventional fixed pitch companion sheaves having the industry standard groove spacing.



B SVS ADJUSTABLE SHEAVES

Wood's B-section SVS stationary control adjustable speed sheaves are available in 2, 3 and 4 groove sizes. When the center distance exceeds 12 inches for 2 groove drives and 16 inches for 3 and 4 groove drives, sheaves with standard groove spacing can be used as the companion sheave.

The B-SVS sheaves are also designed to accept A V-belts. The table below lists the P.D. Range for both A and B V-belts.

B SVS SHEAVES 2, 3 & 4 GROVE

Product No.	Pitch Diameter		O.D.	Stock Bores	Max. Bore	Wt.
	A	B				
SVS49B2	3.62-4.75	3.91-5.31	5.25	7/8, 1-1/8, 1-3/8	1-3/8	14.3
SVS49B3	3.62-4.75	3.91-5.31	5.25	1-1/8, 1-3/8	1-3/8	17.5
SVS49B4	3.62-4.75	3.91-5.31	5.25	1-1/8, 1-3/8	1-3/8	20.0
SVS54B2	4.15-5.25	4.41-5.81	5.75	7/8, 1-1/8, 1-3/8	1-3/8	15.5
SVS54B3	4.15-5.25	4.41-5.81	5.75	1-1/8, 1-3/8	1-3/8	19.0
SVS54B4	4.15-5.25	4.41-5.81	5.75	1-1/8, 1-3/8	1-3/8	22.5
SVS59B2	4.62-5.75	4.91-6.31	6.25	1-1/8, 1-3/8, 1-5/8	1-7/8	18.8
SVS59B3	4.62-5.75	4.91-6.31	6.25	1-1/8, 1-3/8, 1-5/8	1-7/8	23.5
SVS59B4	4.62-5.75	4.91-6.31	6.25	1-3/8, 1-5/8, 1-7/8	1-7/8	27.0
SVS64B2	5.15-6.25	5.41-6.81	6.75	1-1/8, 1-3/8, 1-5/8	1-7/8	20.8
SVS64B3	5.15-6.25	5.41-6.81	6.75	1-3/8, 1-5/8, 1-7/8	1-7/8	24.8
SVS64B4	5.15-6.25	5.41-6.81	6.75	1-5/8, 1-7/8	1-7/8	27.3
SVS69B2	5.65-6.75	5.91-7.31	7.25	1-1/8, 1-3/8, 1-5/8	1-7/8	22.3
SVS69B3	5.65-6.75	5.91-7.31	7.25	1-3/8, 1-5/8, 1-7/8	1-7/8	27.0
SVS69B4	5.65-6.75	5.91-7.31	7.25	1-5/8, 1-7/8	1-7/8	27.3
SVS74B2	6.15-7.25	6.41-7.81	7.75	1-1/8, 1-3/8, 1-5/8	2-3/8	26.3
SVS74B3	6.15-7.25	6.41-7.81	7.75	1-5/8, 1-7/8	2-3/8	32.0
SVS74B4	6.15-7.25	6.41-7.81	7.75	1-5/8, 1-7/8, 2-1/8	2-3/8	37.3
SVS84B2	7.15-8.25	7.41-8.81	8.75	1-3/8, 1-5/8	2-3/8	29.0
SVS84B3	7.15-8.25	7.41-8.81	8.75	1-3/8, 1-5/8, 1-7/8	2-3/8	32.0
SVS84B4	7.15-8.25	7.41-8.81	8.75	1-5/8, 1-7/8, 2-1/8	2-3/8	43.0
SVS94B2	8.15-9.25	8.41-9.81	9.75	1-3/8, 1-5/8	2-3/8	32.5
SVS94B3	8.15-9.25	8.41-9.81	9.75	1-5/8, 1-7/8	2-3/8	42.0
SVS94B4	8.15-9.25	8.41-9.81	9.75	1-5/8, 1-7/8, 2-1/8	2-3/8	50.3

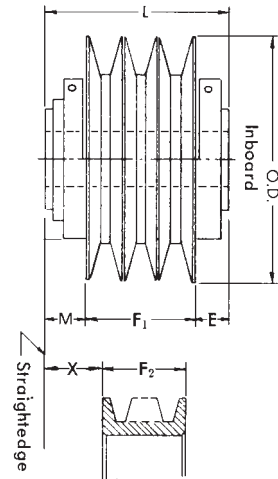

Type 1

Product No. Example: SVS64B3 with 1-3/8" Bore = SVS64B3138 (Product No.)

DIMENSIONS

No. of Grooves	L	F ₁		E		M		F ₂	X	F ₂	X
		Min.	Max.	Min.	Max.	Min.	Max.				
2	4-3/16	1-9/16	2-7/16	7/8	1-5/16	7/8	1-5/16	1-3/4	1-7/32	1-15/16	1-1/8
3	5-5/16	2-1/4	3-9/16	7/8	1-5/16	7/8	1-3/4	2-1/2	1-27/32	2-7/8	1-11/32
4	6-7/16	3	4-11/16	7/8	1-23/32	7/8	1-23/32	3-1/4	1-19/32	3-13/16	1-5/16

These dimensions would apply if Companion Sheaves having wide groove spacing are used.

C SVS ADJUSTABLE SHEAVES



Wood's C-section stationary control adjustable speed sheaves are available in 2, 3 & 4 groove sizes. When the center distance exceeds 19 inches for 2 groove drives and 25 inches for 3 and 4 groove drives, sheaves with standard groove spacing can be used as the companion sheave.

C SVS SHEAVES 2, 3 & 4 GROOVE

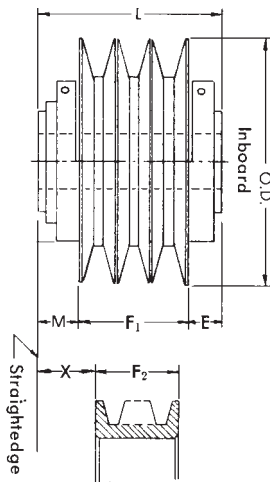

Type 1

Product No.	Pitch Diameter	O.D.	Stock Bores	Max. Bore	Wt.
SVS92C2	7.4-9.6	9.56	1-5/8, 1-7/8	2-1/2	40.5
SVS92C3	7.4-9.6	9.56	1-5/8, 1-7/8, 2-1/8	2-1/2	54.0
SVS92C4	7.4-9.6	9.56	2-1/8, 2-3/8	2-1/2	63.0
SVS102C2	8.4-10.6	10.56	1-5/8, 1-7/8, 2-1/8	2-1/2	44.3
SVS102C3	8.4-10.6	10.56	1-7/8, 2-1/8, 2-3/8	2-1/2	59.0
SVS102C4	8.4-10.6	10.56	2-1/8, 2-3/8	2-1/2	71.8
SVS107C2	8.9-11.1	11.06	1-5/8, 1-7/8, 2-1/8	2-1/2	49.3
SVS107C3	8.9-11.1	11.06	1-7/8, 2-1/8, 2-3/8	2-1/2	62.8
SVS107C4	8.9-11.1	11.06	2-1/8, 2-3/8	2-1/2	76.0
SVS112C2	9.4-11.6	11.56	1-5/8, 1-7/8, 2-1/8	2-1/2	50.5
SVS112C3	9.4-11.6	11.56	1-7/8, 2-1/8, 2-3/8	2-1/2	68.3
SVS112C4	9.4-11.6	11.56	2-1/8, 2-3/8	2-1/2	82.5
SVS117C2	9.9-12.1	12.06	1-5/8, 1-7/8, 2-1/8	2-1/2	50.5
SVS117C3	9.9-12.1	12.06	1-7/8, 2-1/8, 2-3/8	2-1/2	69.5
SVS117C4	9.9-12.1	12.06	2-1/8, 2-3/8	2-1/2	85.5
SVS127C2	10.9-13.1	13.06	1-5/8, 1-7/8, 2-1/8	2-1/2	59.8
SVS127C3	10.9-13.1	13.06	1-7/8, 2-1/8, 2-3/8	2-1/2	76.0
SVS127C4	10.9-13.1	13.06	2-1/8, 2-3/8	2-1/2	91.0

Product No. Example: SVS92C2 with 1-5/8" Bore = SVS92C2158 (Product No.)

DIMENSIONS

No. of Grooves	L	F ₁		E		M		F ₂	X	F ₂	X
		Min.	Max.	Min.	Max.	Min.	Max.				
2	5-1/4	2-1/16	3-1/4	1	1-19/32	1	1-19/32	2-3/8	1-7/16	2-3/8	1-5/16
3	6-7/8	3	4-3/4	1	1-9/16	1-1/8	2-5/16	3-3/8	2-13/32	3-7/8	1-23/32
4	8-9/16	3-15/16	6-5/16	1-1/8	2-5/16	1-1/8	2-5/16	4-3/8	2-3/32	5-1/8	1-23/32

These dimensions would apply if Companion Sheaves having wide groove spacing are used.

