

Gen 2

Clutch/Electrically Released Brake UniModule

UM-50FBC, UM-100FBC, UM-180FBC

P-273-9
819-0530

Installation Instructions



Vented



Enclosed Version Optional



An Altra Industrial Motion Company

Contents

Mounting to a C-Face Motor	3
Mounting to a Reducer	4
Installing the Base Mount	4
Installing the Motor Mount Bracket	4
Mounting to other Power Transmission Components	5
Electrical Connections	6
FB Brake Release Adjustment	6
Troubleshooting-Electrical	7
Troubleshooting-Mechanical	7
Enclosed UniModule Option	9
Warranty	BC

⚠ WARNING Failure to follow these instructions may result in product damage, equipment damage, and serious or fatal injury to personnel.

⚠ WARNING The equipment covered by this installation manual must be installed in accordance with these instructions. Failure to do so may damage the equipment and void the warranty.

Warner Electric UniModules are designed to National Electrical Manufacturers Association (NEMA) standards. They can be mounted to common NEMA C-Face motors and reducers as well as common power transmission drive components.

The 1020FBC UniModule is designed to mount to the face of a C-Face motor as noted in Table 1.

Corresponding NEMA Frame Sizes

UM Size	Old NEMA	New NEMA	Shaft Dia.	C-Face Pilot Dia.
50	56 C	48 Y	5/8"	4-1/2"
100	56 C	48 Y	5/8"	4-1/2"
180	182 C	143 TC	7/8"	4-1/2"
	184 C	145 TC		

Table 1

The 2030FBC UniModule is designed to mount using a base mounting kit. This allows the modules to be mounted as a separate drive unit driven from the prime mover by V-belts, chain and sprockets, couplings, timing belts and other standard power transmission components.

(For UniModule sizes 210 and 215 please refer to Warner Electric manual P-273-2)

For These UM FBC Combinations

Use These Installation Steps:

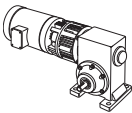
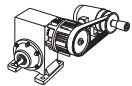
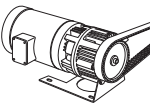
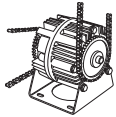
	UniModule Clutch/Brake between C-Face Motor and Reducer 1020FBC	Mounting to a Motor Mounting to a Reducer Electrical Connections Brake Release Adjustment
	UniModule Clutch/Brake 2030FBC	Mounting to other Power Transmission Components Electrical Connections Brake Release Adjustment
	Motor Mount Module Clutch/Brake on a C-Face Motor 1020FBC-M	Mounting to a Motor Installing the Motor Mount Bracket Mounting to other Power Transmission Components Electrical Connections Brake Release Adjustment
	Base Mounted UniModule Clutch/Brake 2030FBC-B	Installing the Base Mount Mounting to other Power Transmission Components Electrical Connections Brake Release Adjustment

Install your specific FBC UniModule combination according to the installation steps specified in the table. Use only those steps indicated for each combination.

Mounting to a C-Face Motor

1. A hardened key is provided with the mounting hardware for FBC UniModules. Insert this key onto the motor shaft (staking the key is necessary).
2. Align the keyway in the bore of the UniModule to the key in the motor shaft and slide the unit onto the motor shaft. The normal alignment of the module to the motor will be with the wire exit/conduit box in the upright (12 o'clock) position as shown in Figure 2.

⚠ WARNING Do not hammer or force the module into position. To do so may damage bearings or cause the friction faces to shift out of alignment.



Figure 2

⚠ CAUTION If anti-fretting lubricant is used on the motor shaft for future ease of removal, ensure that any excess is wiped off before unit assembly to avoid lubricant contaminating the clutch or brake friction faces.

3. Secure the FBC UniModule to the motor with the four (4) long mounting tie-bolts provided. Tighten the four (4) bolts

alternately to ensure even alignment of the module. Tighten them to 30-35 foot pounds.

4. Next secure the clutch rotor and fan assembly to the motor shaft by tightening the two (2) setscrew as follows:
 - a. There are two (2) access slots on either side of the UniModule. A long Allen wrench can be used to tighten the two setscrews (90° apart) which secure the clutch rotor and fan assembly to the motor shaft.
 - b. Alternately align each setscrew with one of the access slots by rotating the clutch rotor and fan assembly through one of the side vents with a small screw driver taking care not to damage the fan. (Figure 3a)

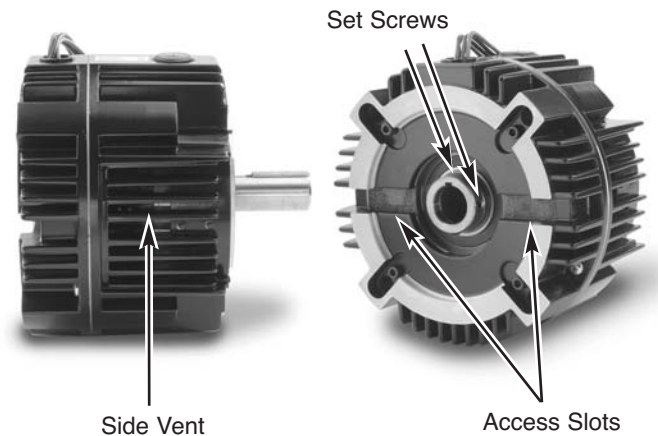

Figure 3a

- c. Using a torque wrench and long Allen socket, tighten the two (2) setscrews to: (Figure 3b)
 - Size 50: 80-85 inch pounds (Requires 5/32 inch Allen wrench)
 - Size 100 or 180: 40-45 inch pounds (Requires 1/8 inch Allen wrench)



Figure 3b

Mounting to a Reducer

1. Warner Electric UniModules are furnished with a hardened key pre-mounted on the output shaft.
2. Align the output shaft and key of the module with the corresponding bore and keyway of the reducer. Slide the assembly together as shown in Figure 4.



Figure 4

3. Bolt the module to the reducer flange. The four (4) bolts that are required (3/8-16UNC2A) are typically provided with the reducer. Tighten to 18-22 foot pounds of torque.

Installing the Base Mount

Model 2030FBC UniModule is designed to be base mounted as shown in Figure 5.

Optional Base Mount Kit,
Warner Electric part numbers:

UM-50/100.....	5370-101-004
UM-180.....	5370-101-002



Figure 5

1. The pilot diameters on each end of the UniModule will mate with the pilot diameters on the base.
2. Secure the base to the UniModule with the four (4) bolts provided. Tighten to 18 to 22 foot pounds.

Installing the Motor Mount Bracket

A Motor Mount Bracket can be installed on the output end of a 1020FBC UniModule to provide a foot mounting for the complete assembly of a UniModule and C-face motor.

Optional Motor Mount Kit,
Warner Electric part numbers:

UM-50/100.....	5370-101-078
UM-180.....	5370-101-079

1. Mount the bracket to the face of the UniModule underneath the UniModule and motor as shown in Figure 6. A pilot diameter on the UniModule mates with a pilot diameter on the bracket.



Figure 6

2. Secure the motor bracket in place with four (4) short bolts and washers provided. Tighten to 18 to 22 foot pounds.

Mounting to other Power Transmission Components

Couplings, pulleys, sprockets or similar power transmission components can be mounted to the input and output shafts of a UniModule.

⚠CAUTION When mounting a pulley or sprocket, ensure that the key is fully engaged within the device hub or bushing.

⚠CAUTION Confirm that the belt or chain tightness meets the maximum side load capability of the UniModule shown in Table 2.

Overhung Load Data (Shaft Side Load)

Overhung load data is provided in this manual for the design engineer concerned with a specific problem in this area. The maximum allowable overhung load which can be applied to the shaft of an UniModule may be determined by the use of the accompanying chart.

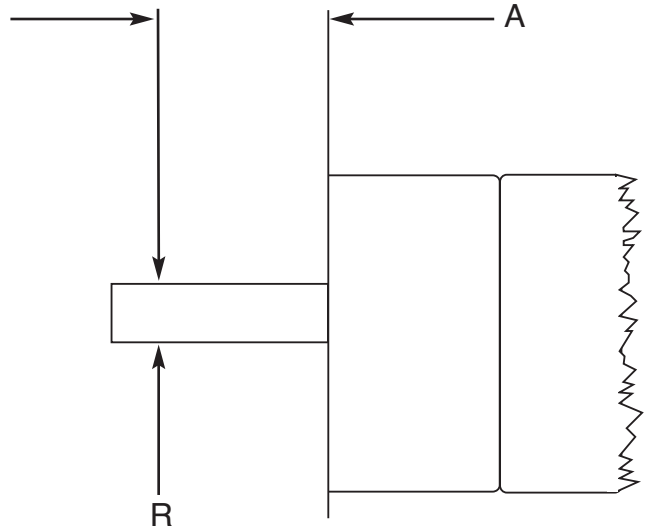

UniModule	Distance Load is Applied from Housing Face "A" Inches	Maximum Load Rating "R" Lbs.
UM-50	1" (Center of Shaft)	177
	2" (End of Shaft)	123
	3"	95
UM-100	1" (Center of Shaft)	192
	2" (End of Shaft)	134
	3"	104
UM-180	1" (Center of Shaft)	192
	2" (End of Shaft)	134
	3"	104

Table 2

Electrical Connections

▲WARNING To avoid injury (or even death), always make certain all power is off before attempting to install or service this device or any electrical equipment.

The conduit connection hole in the UniModules are threaded for standard ½ inch conduit connection. UniModule FBC clutches and brakes operate on DC voltage. Warner Electric offers a complete line of electronic controls to meet the needs of almost any clutch/brake application. Each Warner Electric control will show the proper wiring connections for its use.

Control Requirements for (FB) Fail Safe Brakes

Electrically Released Permanent Magnet Brakes must use one of Warner Electric's adjustable power supplies. See the Service Installation sheet included with the power supply for connection information.

Note: All Electrically Released Permanent Magnet Modules are polarity sensitive. Therefore, the (+) red wire must be connected to the positive terminal and the (-) black wire to the negative terminal. Potentiometer control will then provide adjustment for the proper brake release point.

When switching a 1020FBC or 2030FBC power must be applied to both the clutch and FB brake simultaneously to engage the clutch and at the same time release the brake.

If a Conduit Box is desired, Warner Electric Conduit Box Kit, part number 5370-101-042, can be purchased separately. The Conduit Box provides two conduit connection holes for standard ½ inch conduit connectors.

FB Brake Release Adjustment

Instructions for setting the optimum release voltage of permanent magnet applied/ electrically released brakes.

▲CAUTION The following procedure will result in the brake releasing and allowing the load to be free to move. Be sure the load is in a safe condition before proceeding with this process.

In a permanent magnet applied/electrically released brake, the attractive force between the brake surfaces is created by permanent magnets. The brake is electrically released by applying DC power to the electro-magnetic coil in the brake that opposes the permanent magnets.

Electrically released brakes are polarity sensitive: the positive lead of the power supply must be connected to the positive (red) lead of the brake and the negative lead of the power supply must be connected to the negative (black) lead of the brake.

The power supply applied to the brake must also be adjustable so that the optimum release voltage for each individual brake can be determined and set.

The following procedure describes how to set the adjustable power supply to the optimum release point of the brake. A volt-meter is required to perform the procedure.

No power is applied to motor during this procedure. Power normally supplied by motor to brake control should be supplied by alternate method.

1. With power off, connect the positive lead of the power supply to the positive (red) lead of the brake and the negative lead of the power supply to the negative (black) lead of the brake.

2. Connect a volt-meter to measure the voltage applied across the brake.
3. Adjust the power supply to its lowest possible output, and then energize the power supply to apply power to the brake only.
4. Starting from the low voltage point, slowly increase the applied voltage while visually watching the brake armature through one of the vent slots and fan slot on either side of the module until the brake armature disengages from the brake magnet. Note and record this voltage reading.
5. Add twenty (20) volts for a 90 volt brake and five (5) volts for a 24 volt brake to this reading and set the supply to this level. This will be the proper release voltage for your setup.
6. With the brake energized, spin the output shaft by hand to insure that it turns freely. If a scraping sound is noted when the output shaft is spun, it means an armature is dragging slightly. This needs to be corrected by repeating brake release adjustment steps 1-5 above and/or performing armature airgap adjustment as described in the **Troubleshooting – Mechanical** section of this instruction.

Troubleshooting - Electrical

If a UniModule is not functioning properly it is best to check for these problems before replacing it.

A standard UniModule FBC clutch/brake requires DC power to function. If power is not reaching the clutch or brake, the clutch will not engage and the brake will not disengage.

A good practice to follow is to check for power at the lead wires to the clutch or brake using a voltmeter.

- If power is present in the proper voltage and current, then skip ahead to the Mechanical Troubleshooting section.
- If power is not present, inspect the lead wires for breaks or cuts.
- If the wires are intact, the problem may be with the power supply or the switch.
- Using a voltmeter, check to see that voltage is leaving the power supply and that the switch is sending power to the clutch or brake.
- Finally, if there is no power leaving the switch or power supply, check the incoming AC power to ensure that it is reaching the power supply.

Electrical Coil Data

		Clutch	Brake	Clutch	Brake	Clutch	Brake
Voltage–D.C.		90	90	24	24	6	6
Resistance	UM-50	452	452	31.8	28.8	1.86	1.86
(OHMS)	UM-100/180	392	392	26.7	26.7	1.81	1.81
Current	UM-50	.199	.199	.755	.833	3.23	3.23
(Amperes)	UM-100/180	.230	.230	.896	.896	3.31	3.31
Power	UM-50	17.9	17.9	18.1	20.0	19.4	19.4
(WATTS)	UM-100/180	20.7	20.7	21.5	21.5	20	20
Coil Build Up	UM-50	52	53	52	53	52	53
Time (ms)	UM-100/180	72	75	72	75	72	70
Coil Decay	UM-50	6.2	5.0	6.2	5.0	6.5	5.0
Time (ms)	UM-100/180	12	10	12	10	12	10

Troubleshooting - Mechanical

Both clutch and FB brake armatures are equipped with an Autogap™ assembly that maintains the proper airgap between friction faces through the life of the product. Each UniModule is airgap adjusted and pre-burnished at the factory, but the airgaps can shift as a result of rough handling during shipping and installation.

An airgap that is too large can prevent the armature from engaging. An airgap that is too small can cause the armature to rub continuously, causing higher running

temperatures and decreased wear life. To reset the airgaps, you will need to access the armatures. Looking through the vents on either side of the housing, you will see the fan on the clutch rotor. Rotate the fan (input) until you see the 1/2 x 1 inch window on the outer periphery of the fan. Through this window, you will be looking between the two armatures of the clutch and brake. (Figures 7 & 8)

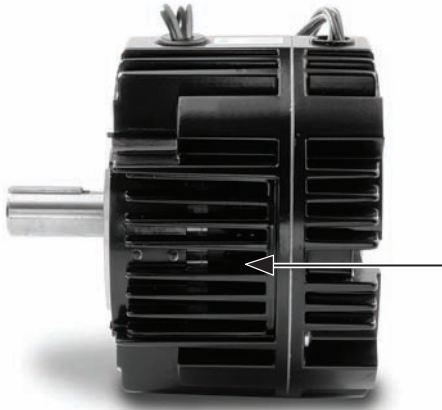

Figure 7

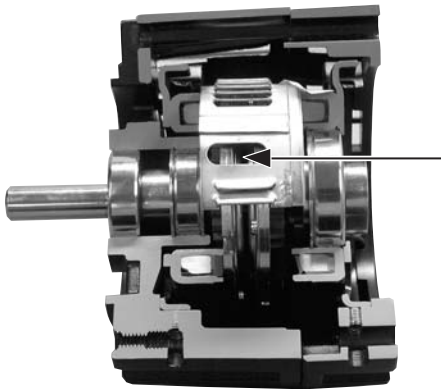

Figure 8

If either armature is too far away from its mating friction surface, it is possible to move it back into adjustment using a flat blade screwdriver. (Figure 9)

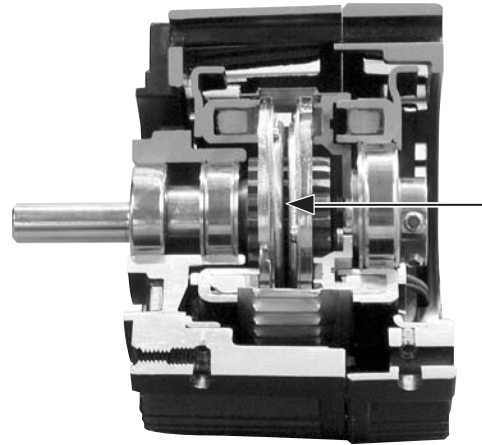

Figure 9

Note: When resetting the clutch or FB brake armature airgap, both the clutch and brake must be released (the brake energized, and the clutch not energized).

This is a three step process.

1. Simply slide the screwdriver through the window. By twisting the screwdriver, it works as a wedge to apply pressure on the back of the armature pushing it toward its mating friction surface.
2. Rotate the output of the unit. The rotor and window should stay in place when you do this. Only the armatures will move.
3. Alternately repeat steps 1 & 2 to ensure that the airgap between the armature and its mating surface is about 1/32 inch and that the armature remains square to its mating surface. (If the armature is uneven, it may engage on just one side giving the appearance of engagement but failing to provide full torque.)

If there is a scraping or rubbing sound when the output shaft is rotated, this means that an armature is dragging and is too close to its mating surface. Simply repeat steps 1-3 above, but place the screwdriver between the face of the armature and its mating friction surface.

Mechanical Data

	UM-50FBC	UM-100/180FBC
Static Torque - lb. ft.	16	30
Maximum Speed - rpm	3600	3600
Average Weight-lbs.		
1020	15.6	18.7
2030	18.4	21.7

Inertia - WR - lb.ft.²

Configuration	50	100/180
1020 input	.021	.047
1020 output	.0195	.050
2030 input	.021	.048
2030 output	.0195	.050

Enclosed UniModule Option

If an Enclosed UniModule is required, an optional Cover Kit, Warner Electric part number 5370-101-076, can be purchased separately to enclose the open vents in the housing.

Each Cover Kit includes two (2) vent covers and four (4) screws needed to convert a vented UniModule to an enclosed design (non-washdown) as shown in Figure 10.



Figure 10

Note: When using this Cover Kit to enclose the module the vent covers should be assembled as the final step.

Notes:

Visit Warner Electric's website at www.warnerelectric.com for dimensional drawings, weights, inertias, and a complete offering of our products including clutches, brakes and clutch/brake controls and service parts.

In addition, Warner Electric module products, controls, and service parts information can be found in our catalog P-1234-WE. Call 815-389-3771 to request any of our catalogs.

Warranty

Warner Electric LLC warrants that it will repair or replace (whichever it deems advisable) any product manufactured and sold by it which proves to be defective in material or workmanship within a period of one (1) year from the date of original purchase for consumer, commercial or industrial use.

This warranty extends only to the original purchaser and is not transferable or assignable without Warner Electric LLC's prior consent.

Warranty service can be obtained in the U.S.A. by returning any defective product, transportation charges prepaid, to the appropriate Warner Electric LLC factory. Additional warranty information may be obtained by writing the Customer Satisfaction Department, Warner Electric LLC, 449 Gardner Street, South Beloit, Illinois 61080, or by calling 815-389-3771.

A purchase receipt or other proof of original purchase will be required before warranty service is rendered. If found defective under the terms of this warranty, repair or replacement will be made, without charge, together with a refund for transportation costs. If found not to be defective, you will be notified and, with your consent, the item will be repaired or replaced and returned to you at your expense.

This warranty covers normal use and does not cover damage or defect which results from alteration, accident, neglect, or improper installation, operation, or maintenance.

Some states do not allow limitation on how long an implied warranty lasts, so the above limitation may not apply to you.

Warner Electric LLC's obligation under this warranty is limited to the repair or replacement of the defective product and in no event shall Warner Electric LLC be liable for consequential, indirect, or incidental damages of any kind incurred by reason of the manufacture, sale or use of any defective product. Warner Electric LLC neither assumes nor authorizes any other person to give any other warranty or to assume any other obligation or liability on its behalf.

WITH RESPECT TO CONSUMER USE OF THE PRODUCT, ANY IMPLIED WARRANTIES WHICH THE CONSUMER MAY HAVE ARE LIMITED IN DURATION TO ONE YEAR FROM THE DATE OF ORIGINAL CONSUMER PURCHASE. WITH RESPECT TO COMMERCIAL AND INDUSTRIAL USES OF THE PRODUCT, THE FOREGOING WARRANTY IS IN LIEU OF AND EXCLUDES ALL OTHER WARRANTIES, WHETHER EXPRESSED OR IMPLIED BY OPERATION OF LAW OR OTHERWISE, INCLUDING, BUT NOT LIMITED TO, ANY IMPLIED WARRANTIES OF MERCHANTABILITY OR FITNESS.

Some states do not allow the exclusion or limitation of incidental or consequential damages, so the above limitation or exclusion may not apply to you. This warranty gives you specific legal rights and you may also have other rights which vary from state to state.

Changes in Dimensions and Specifications

All dimensions and specifications shown in Warner Electric catalogs are subject to change without notice. Weights do not include weight of boxing for shipment. Certified prints will be furnished without charge on request to Warner Electric.



Warner Electric LLC
449 Gardner Street • South Beloit, IL 61080
815-389-3771 • Fax: 815-389-2582
www.warnerelectric.com
An Altra Industrial Motion Company