

UM-C Series UniModule – Ceramic Faced

PHASE 4

High Performance with Extended Life

UniModules with ceramic friction material are pre-burnished during manufacturing to provide rated torque performance upon start up. They have been designed to mate easily with industry standard motors, reducers and other power transmission components.

- Bolt-it-down, wire-it-up... it's ready to go
- Available in 3 sizes; 50, 180 and 210 and 2 configurations; 1020 and 2030
- Standard voltages available 6V, 24V and 90V DC
- C-face or foot mounted
- No maintenance required
- Accurate positioning when used with CBC-1000 Indexer and CBC-700 OEX control

The Ceramic Difference . . .

Extended Life for High Cycle Rate Use

Ceramic faced clutches and brakes have been designed specifically for rapid cycling applications to satisfy today's needs for high speed equipment. Ceramic friction material provides excellent wear resistance that extends life 3 to 5 times that of standard clutch/brakes in demanding applications.

Consistent Torque and Cycle Repeatability

Preloaded armatures keep the ceramic friction surfaces lightly in contact to provide consistent torque and cycle-to-cycle repeatability. Variation is reduced by up to 30% over standard units. Autogap™ is not required.

Controllability – Smooth Start/Stop

With the ceramic friction surfaces always in contact, dynamic torque response is fast and precise. When used with a CBC-700 over-excitation control and CBC-1000 programmable counter, exceptional closed loop clutch/brake performance can be achieved approaching that of more expensive motion control technologies – The PerformancePlus difference!



GEN 2 Design
Sizes 50 & 180



UM-C Product Life

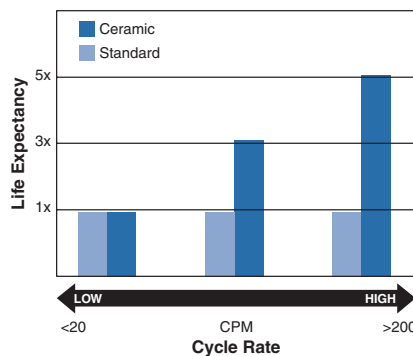

UM-C Cycle Repeat

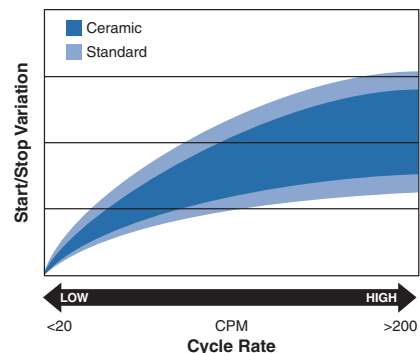

Ceramic UniModule clutch/brake units may be mounted directly to NEMA C-face motors and reducers, or can be base mounted.

1. Determine Mounting Configuration

a. NEMA C-face Mounting (1020 Configuration)

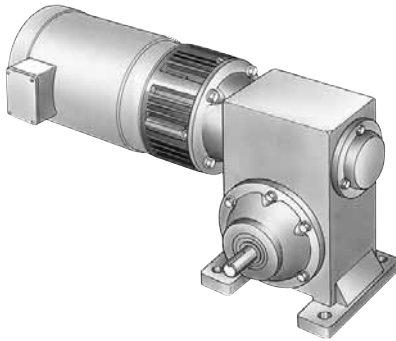

To select the correct Ceramic UniModule package, determine the NEMA frame size of your motor and/or reducer, and choose the corresponding size UniModule from the Frame Size Selection chart.

Frame Size Selection

NEMA Frame Size	UniModule Size
56C/48Y	UM-50-C
182C/143TC 184C/145TC	UM-180-C
213C/182TC 215C/184TC	UM-210-C

b. Base Mount (2030 Configuration)

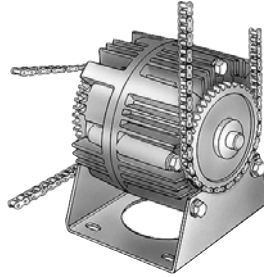

Ceramic UniModule assemblies may be mounted as separate drive units driven from the prime mover by V-belts, chain and sprockets, couplings, timing belts and other standard power transmission components.

Select the correct size module from the Horsepower vs. Shaft Speed chart by determining the motor horsepower and RPM at the module location. The correct size UniModule is shown at the intersection of the HP and operating speed. For additional sizing information, refer to the technical sizing procedure (step 2).

2. Determine Technical Requirements

Technical considerations for sizing and selection are torque and heat dissipation. Each merits careful consideration, especially heat dissipation as over time, use in excessive temperature environments will have an adverse effect on bearing life and coil wire insulation integrity.

Compare the calculated torque requirement with the average dynamic torque ratings. Select a unit with adequate torque. If the unit selected on torque is different than the unit selected based on heat, select the larger size unit.

Horsepower vs. Shaft Speed

HP	SHAFT SPEED AT CLUTCH (IN RPM)																	
	100	200	300	400	500	600	700	800	900	1000	1100	1200	1500	1800	2000	2400	3000	3600
1/4													UM-50-C					
1/2													UM-180-C					
3/4													UM-180-C					
1													UM-210-C					
1-1/2													UM-210-C					
2													UM-210-C					
3													UM-210-C					
5													UM-210-C					
7-1/2													UM-210-C					
10													UM-210-C					

UM-C Series UniModule – Ceramic Faced

a. Heat Dissipation Sizing

Friction surfaces slip during the initial period of engagement and, as a result, heat is generated. The clutch/brake selected must have a heat dissipation rating greater than the heat generated by the application. Therefore, in high inertia or high cycle rate applications, it is necessary to check the heat dissipation carefully. Inertia, speed and cycle rate are the required parameters.

Heat dissipation requirement is calculated as follows:

$$E = 1.7 \times WR^2 \times (N/100)^2 \times F$$

where:

$$E = \text{Heat (lb. ft./min.)}$$

WR^2 = Total reflected inertia at the clutch/brake shaft. Include the clutch/brake output inertia. (lb.ft.²)

N = Speed in revolutions per minute (RPM)

F = Cycle rate in cycles per minute (CPM)

Compare the calculated heat generated in the application to the unit ratings using the heat dissipation curves. Select the appropriate unit that has adequate heat dissipation ability.

Heat Dissipation Curves

UM-50-C

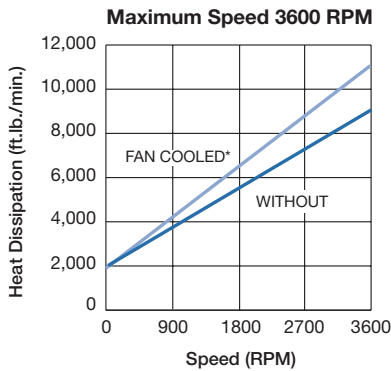

UM-180-C

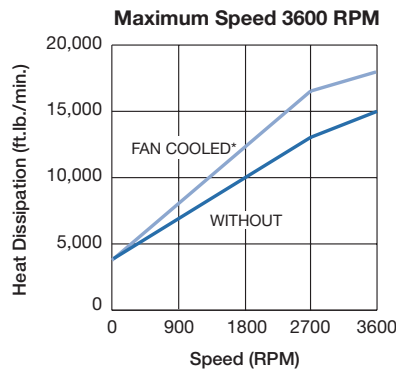

UM-210-C

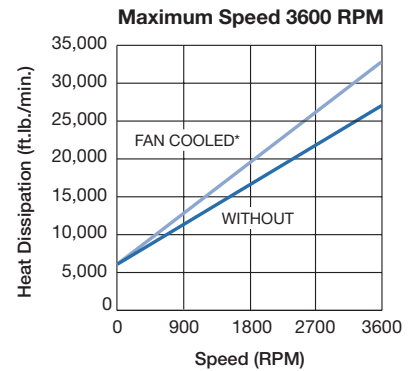

* Fan accessory kit available for 1020 configuration

b. Torque Sizing

For most applications, the correct size clutch/brake can be selected from the Horsepower vs. Shaft Speed chart on page 60. Determine the motor horsepower and the RPM at the clutch/brake. The correct size unit is shown at the intersection of horsepower and shaft speed.

If the static torque requirements are known, refer to the technical ratings chart to select a unit.

For some applications, the torque requirement is determined by the time allowed to accelerate and decelerate the load. (This time is generally specified in milliseconds.) For these applications, it is necessary to determine the torque requirement based on load inertia and the time allowed for engagement.

The torque requirements are calculated as follows:

$$T = (WR^2 \times N) / (308 \times t)$$

where:

T = Average Dynamic Torque (lb. ft.)

WR^2 = Total reflected inertia at the clutch/brake shaft. Include the clutch/brake output inertia. (lb. ft.²)

N = Speed in revolutions per minute (RPM)

t = Time allowed for the engagement (sec)

C-face Clutch/Power-on Brake Dynamic Torque Curves

Size 50

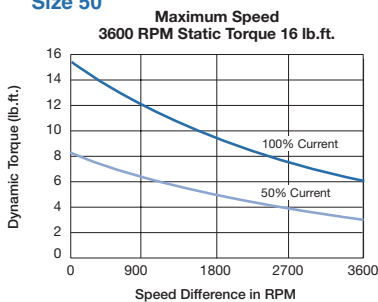

Size 180

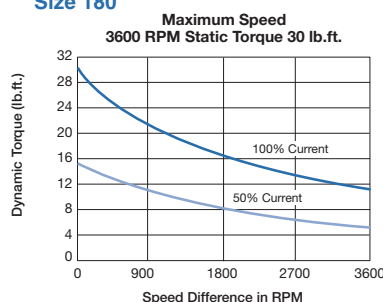

Size 210

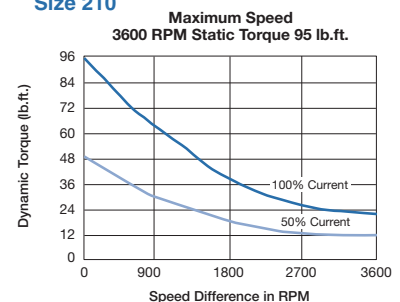

UniModule – Ceramic Faced | UM-C Series

Selection/Ordering Information

Specifications (Blue shaded areas indicate GEN 2 design)

UniModule Size	Shaft Dia.	Static Torque lb. ft.	Horsepower	Max. RPM	Voltage DC	NEMA Frame Size
UM50-C	5/8"	16	1/4-3/4	3600	6, 24 and 90	56C/48Y
UM180-C	7/8"	30	1-2	3600	6, 24 and 90	182C/143TC 184C/145TC
UM210-C	1-1/8"	95	3-5	3600	6, 24 and 90	213/182TC 215C/184TC

3. Select Accessories

Warner Electric UniModules can be fitted with several accessories to extend their capacity and ease of mounting.

a. Conduit Box

NEMA 4 and UL listed.

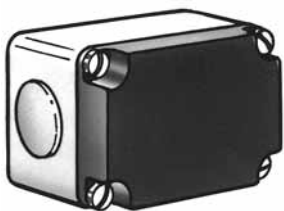

c. Fan Kit (1020 only)

Extends the thermal capacity of any size UM. Mounts between motor and UM, includes shaft fan, guard and hardware.



4. Select Control

Warner Electric manufactures clutch/brake controls to meet several system functions including:

- On/Off
- Torque adjust
- Overexcitation
- Position loop

Many requirements beyond function can impact control selection. See the Controls Section in the Clutch/Brake catalog P-1234 on page 141 for complete information.

b. Mounting Brackets

Two styles of mounting brackets are available for simplified installation. The base mount is used with the 2030 configuration. A motor mount is also available and provides sturdy support for the 1020 and a motor.

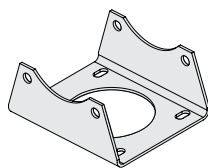

Base Mount

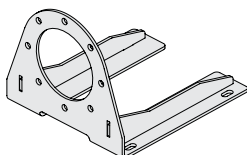

Motor Mount
For 50 & 180 sizes

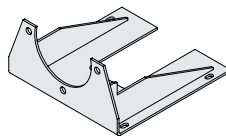

Motor Mount
For 210 size

UniModule – Ceramic Faced | UM-C Series

UM-1020-C Motor Clutch/Brake Combination

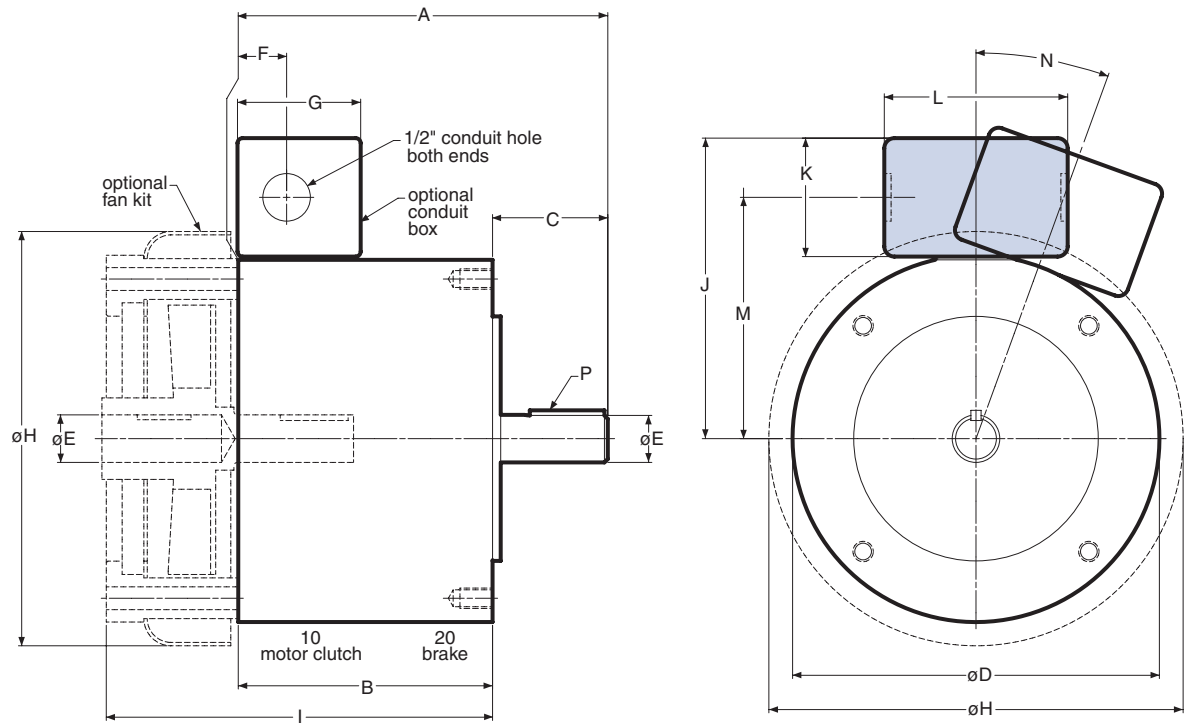

Dimensions (Blue shaded areas indicate GEN 2 design)

Size	A	B	C	D	E	F	G	H
50	6.720	4.680	2.040	6.750	.625	.890	2.267	7.620
180	6.801	4.680	2.121	6.750	.875	.890	2.267	7.620
210	9.391*	6.422*	2.500	9.250	1.125	.500	2.267	10.187

Size	I	J	K	L	M	N	P
50	7.110	5.516	2.180	3.250	4.426	0°	3/16 x 3/16
180	7.110	5.516	2.180	3.250	4.426	0°	3/16 x 3/16
210	9.297	6.859	2.180	3.250	5.766	20°	1/4 x 1/4

*Dimension includes the .500 thick adapter. Required for C-face mounting to a motor.

Specifications (Blue shaded areas indicate GEN 2 design)

UniModule Size	Static Torque lb. ft.	Horsepower	Max. RPM	Voltage DC	NEMA Frame Size
UM50-C	16	1/4-3/4	3600	6, 24 and 90	56C/48Y
UM180-C	30	1-2	3600	6, 24 and 90	182C/143TC 184C/145TC
UM210-C	95	3-5	3600	6, 24 and 90	213/182TC 215C/184TC

For standard NEMA frame dimensions, see page 64.

Only 50 and 180 sizes of the models listed will be converted to the new GEN 2 design. 210 size will continue to be offered in the original design and will not be converted.

UM-C Series UniModule – Ceramic Faced

UM-2030-C Brake/Input Clutch Combination UM-2030-C-B Brake/Input Clutch Combination–Base Mounted

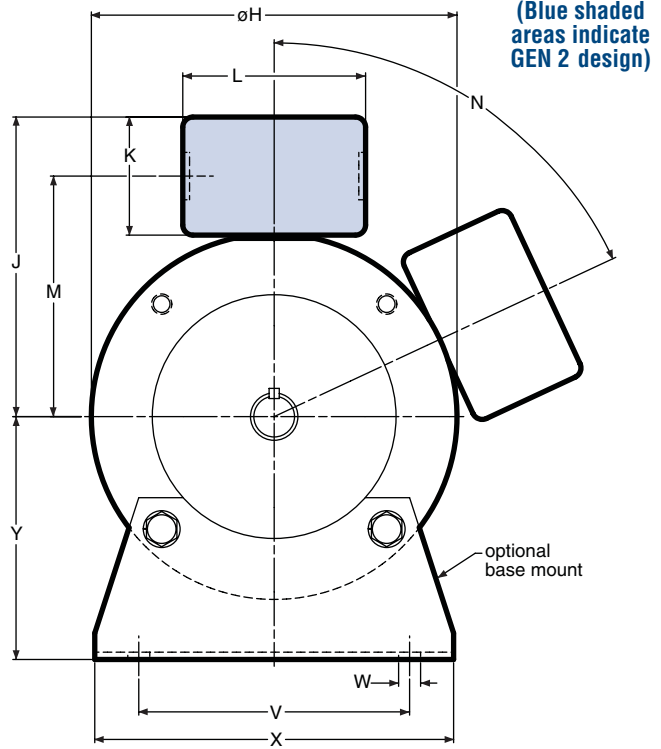
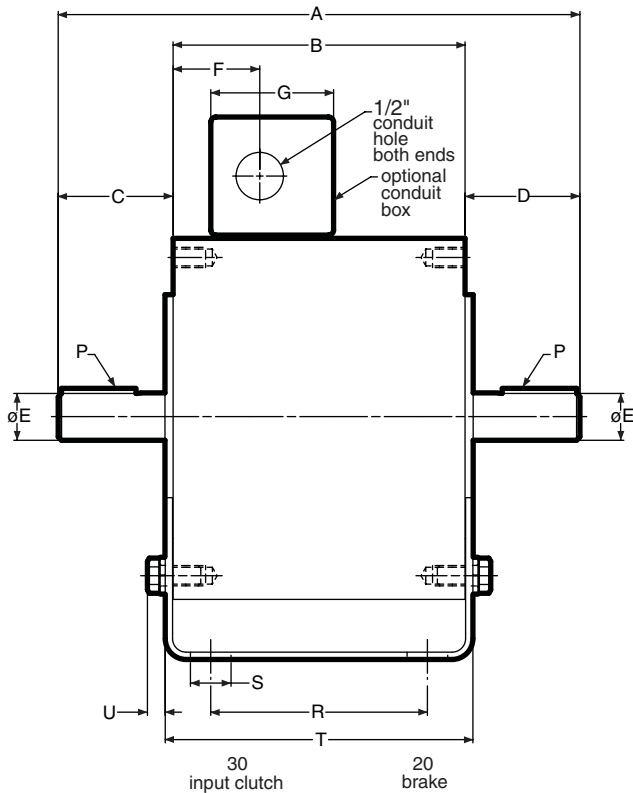

(Blue shaded areas indicate GEN 2 design)

Note: Mounting base is optional and must be ordered separately.

Dimensions (Blue shaded areas indicate GEN 2 design)

Size	A	B	C	D	E	F	G	H	J	K	L	M
50	9.492	5.390	2.062	2.040	.625	1.600	2.267	6.750	5.516	2.180	3.250	4.426
180	9.632	5.390	2.121	2.121	.875	1.600	2.267	6.750	5.516	2.180	3.250	4.426
210	12.969	7.719	2.500	2.500	1.125	1.812	2.267	9.250	6.859	2.180	3.250	5.766

Size	N	P	R	S	T	U	V	W	X	Y
50	0°	3/16 x 3/16	4.000	.800	5.680	.329	5.000	.406	6.000	3.500
180	0°	3/16 x 3/16	4.000	.750	5.680	.329	5.000	.406	6.625	4.500
210	65°	1/4 x 1/4	6.000	.750	8.260	.437	7.750	.534	9.000	5.250

For standard NEMA frame dimensions, see page 64.

Specifications (Blue shaded areas indicate GEN 2 design)

UniModule Size	Static Torque lb. ft.	Horsepower	Max. RPM	Voltage DC	NEMA Frame Size
UM50-C	16	1/4-3/4	3600	6, 24 and 90	56C/48Y
UM180-C	30	1-2	3600	6, 24 and 90	182C/143TC 184C/145TC
UM210-C	95	3-5	3600	6, 24 and 90	213/182TC 215C/184TC

For standard NEMA frame dimensions, see page 64.

Only 50 and 180 sizes of the models listed will be converted to the new GEN 2 design. 210 size will continue to be offered in the original design and will not be converted.