

Electric Brakes and Clutches

ATT Series – Advanced Technology Brakes and Clutches

Advanced Technology – A new design concept!

Warner Electric's ATT Series clutches and brakes are rugged and durable.

Besides providing the ultimate in long life and durability, the ATT units are easily repairable... and, for the first time, mounting a standard sheave, pulley or sprocket to the clutch is a snap.

AT Clutches and Brakes are completely assembled at the factory and have been specifically designed to match the torque ratings of standard motors, reducers, and other power transmission components. Easy to select and easy to install.

Features:

ATT Tension Clutches and Brakes

- Ideal for intermediate range applications
- Both brake and clutch models for winders and unwinders
- .284 to .9 thermal horsepower capacity
- Brake wear faces replaceable on the shaft for limited downtime
- Full range of control options. See pages 40-41.



Unit Size	Maximum RPM	Continuous ¹ Dynamic Torque	Overcurrent E-Stop Torque
ATT Brakes			
ATTB-25	3600	8 lb.ft.	15 lb.ft
ATTB-55	3600	15 lb.ft.	21 lb.ft
ATTB-115	3600	62 lb.ft.	83 lb.ft.
ATT Clutches			
ATTC-25	3600	7 lb.ft.	*2
ATTC-55	3600	12 lb.ft.	*
ATTC-115	3600	41 lb.ft.	*

Notes

1. Dynamic torque is constant over a speed range of 0–600 RPM
2. Overcurrent is not used on clutch applications for tensioning

Continuous Operation

Thermal HP vs. Selection RPM

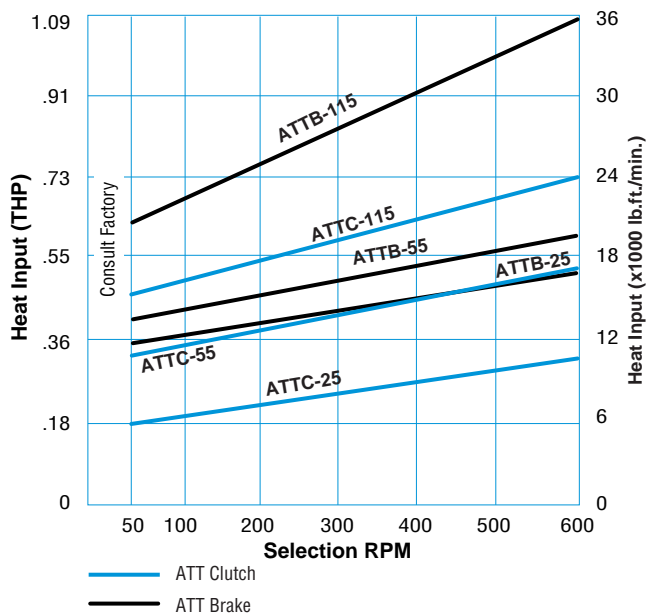

Electric Brakes and Clutches

ATT Series – Advanced Technology Brakes and Clutches

Special Coil Designs

High temperature coil wire improves durability in the face of high temperature environments and high cycle rates or high inertia cycling that generate large amounts of heat. High temperature Teflon leads are very resistant to accidental abrasion and cutting.



Replaceable Friction Discs

Friction disc is designed as separate assembly from clutch rotor or brake magnet, allowing for replacement of the wear surface without the expense of replacing other valuable unit components. Provides superior wear life with reduced engagement noise level.

Advanced Technology Tension Clutches and Brakes

- Ideal for intermediate range applications
- Both brake and clutch models for winders and unwinders
- .284 to .9 thermal horsepower capacity
- Wear faces replaceable on the shaft for limited downtime
- Full range of control options

Complete Control Capability



Optional Accessories

Warner Electric offers a number of optional accessories as well as rebuild kits, which may make an ATT clutch or

brake easier to apply to your machine. See pages 40-41 for controls.

Unit	Model No.	Clutch Restraining Strap	Repair Kits	
			Friction Face Replacement	Rebuild
Clutch	ATTC-25	5162-101-004	5161-101-008	5161-101-009
	ATTC-55	5162-101-004	5162-101-008	5162-101-009
	ATTC-115	5163-101-004	5163-101-008	5163-101-009
Brake	ATTB-25	—	5161-101-008	—
	ATTB-55	—	5162-101-008	—
	ATTB-115	—	5163-101-008	—

Bore Sizes/Part Numbers

Size	Bore Size (Inch)	24 VDC		90 VDC	
		Clutch (ATTC)	Brake (ATTB)	Clutch (ATTC)	Brake (ATTB)
ATT-25	1/2"	5161-271-021	5191-6	5161-271-025	5191-10
	5/8"	5161-271-022	5191-7	5161-271-026	5191-11
	3/4"	5161-271-023	5191-8	5161-271-027	5191-12
	7/8"	5161-271-024	5191-9	5161-271-028	5191-13
ATT-55	3/4"	5162-271-021	5192-6	5162-271-025	5192-10
	7/8"	5162-271-022	5192-7	5162-271-026	5192-11
	1"	5162-271-023	5192-8	5162-271-027	5192-12
	1-1/8"	5162-271-024	5192-9	5162-271-028	5192-13
ATT-115	1-1/8"	5163-271-021	5193-6	5163-271-025	5193-10
	1-1/4"	5163-271-022	5193-7	5163-271-026	5193-11
	1-3/8"	5163-271-023	5193-8	5163-271-027	5193-12
	1-1/2"	5163-271-024	5193-9	5163-271-028	5193-13

Electric Brakes and Clutches

ATT Series – Advanced Technology Brakes and Clutches

ATTB Brake

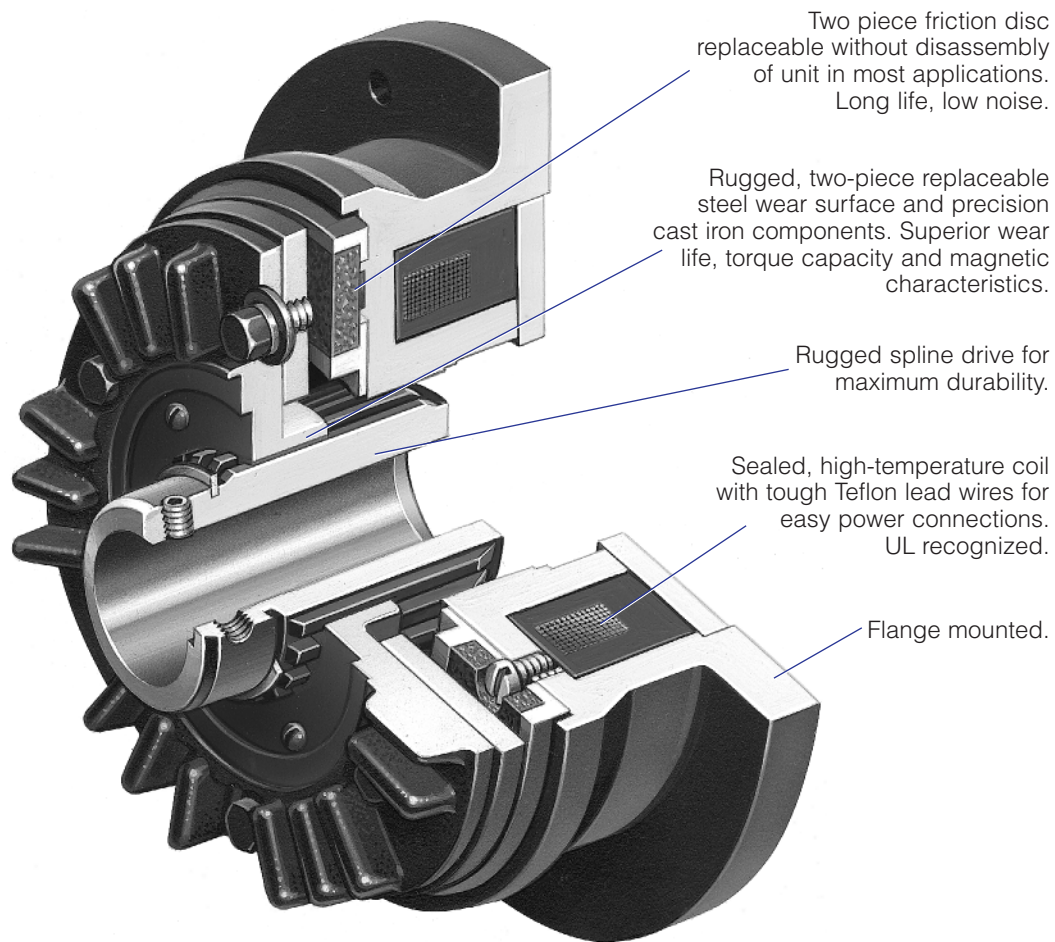

Specifications

Unit	Model No.	Mechanical Data			Electrical Data		
		Total Weight (lbs.)	Max Speed (RPM)	Inertia WR^2 (lb.ft. ²)	24 VDC		
					Resistance (ohms)	Current (amperes)	Power (watts)
	ATTB-25	7	3600	0.038	20.6	1.16	28.0
Brake	ATTB-55	15	3600	0.126	19.6	1.22	29.4
	ATTB-115	24	3600	0.383	16.5	1.46	34.9

Electric Brakes and Clutches

ATT Series – Advanced Technology Brakes and Clutches

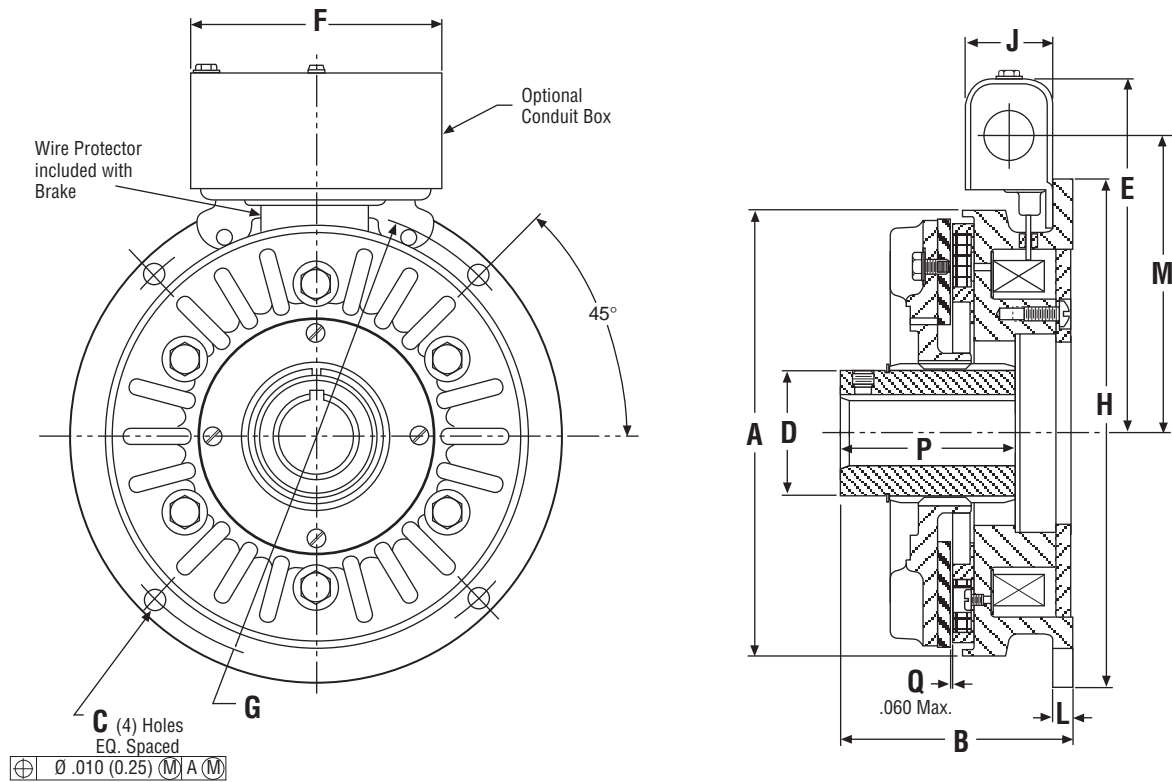

Customer shall maintain:

1. Squareness of brake mounting face with armature hub shaft within .006 T.I.R.
2. Concentricity of brake mounting pilot diameter with armature hub shaft within .010 T.I.R.

Shaft Bore and Keyway Dimensions

Model	Unit	Bore	Key
ATTB-25		.5025	(12.76)
		.5005	(12.71)
ATTB-25		.6275	(15.94)
		.6255	(15.89)
ATTB-25		.7525	(19.11)
		.7505	(19.06)
ATTB-25		.8775	(22.29)
		.8755	(22.24)

Model	Unit	Bore	Key
ATTB-55		1.0025	25.46
		1.0005	25.41
ATTB-55		1.1275	28.64
ATTB-115		1.1255	28.59
ATTB-115		1.2525	31.81
		1.2505	31.76
ATTB-115		1.7775	34.99
		1.3755	34.94
ATTB-115		1.5025	38.16
		1.5005	38.11

Model	A Max. Dia.	B Max.	C Min. Dia.
ATTB-25	4.822 (122.48)	2.730 (69.34)	.264 (6.70)
ATTB-55	6.271 (159.28)	3.010 (77.97)	.330 (8.38)
ATTB-115	7.906 (200.81)	3.625 (12.07)	.330 (8.38)

() denotes millimeters

Model	D Max.	E Nom.	F Max.	G Dia.	H Pilot Dia.	J Nom.	K Max.	L Nom.	M Max.	P
ATTB-25	1.345 (34.16)	4.748 (120.60)	3.767 (95.68)	5.250 (133.35)	5.625/5.623 (142.87/142.82)	1.544 (39.22)	.225 (5.71)	3.586 (91.08)	2.080 (52.83)	4.375 (111.13)
ATTB-55	1.765 (44.83)	5.37 (136.40)	3.767 (95.68)	6.875 (174.62)	7.315/7.313 (187.33/181.21)	1.544 (39.22)	.491 (12.47)	4.208 (106.88)	1.960 (49.87)	4.925 (125.10)
ATTB-115	2.150 (54.61)	6.278 (159.46)	3.767 (95.68)	8.500 (215.90)	9.000/8.998 (228.60/228.55)	1.544 (39.22)	.463 (11.76)	5.116 (129.95)	3.105 (78.87)	5.967 (151.56)

For replacement parts list and exploded view drawing, see page 160.

Electric Brakes and Clutches

ATT Series – Advanced Technology Brakes and Clutches

ATTC Clutch

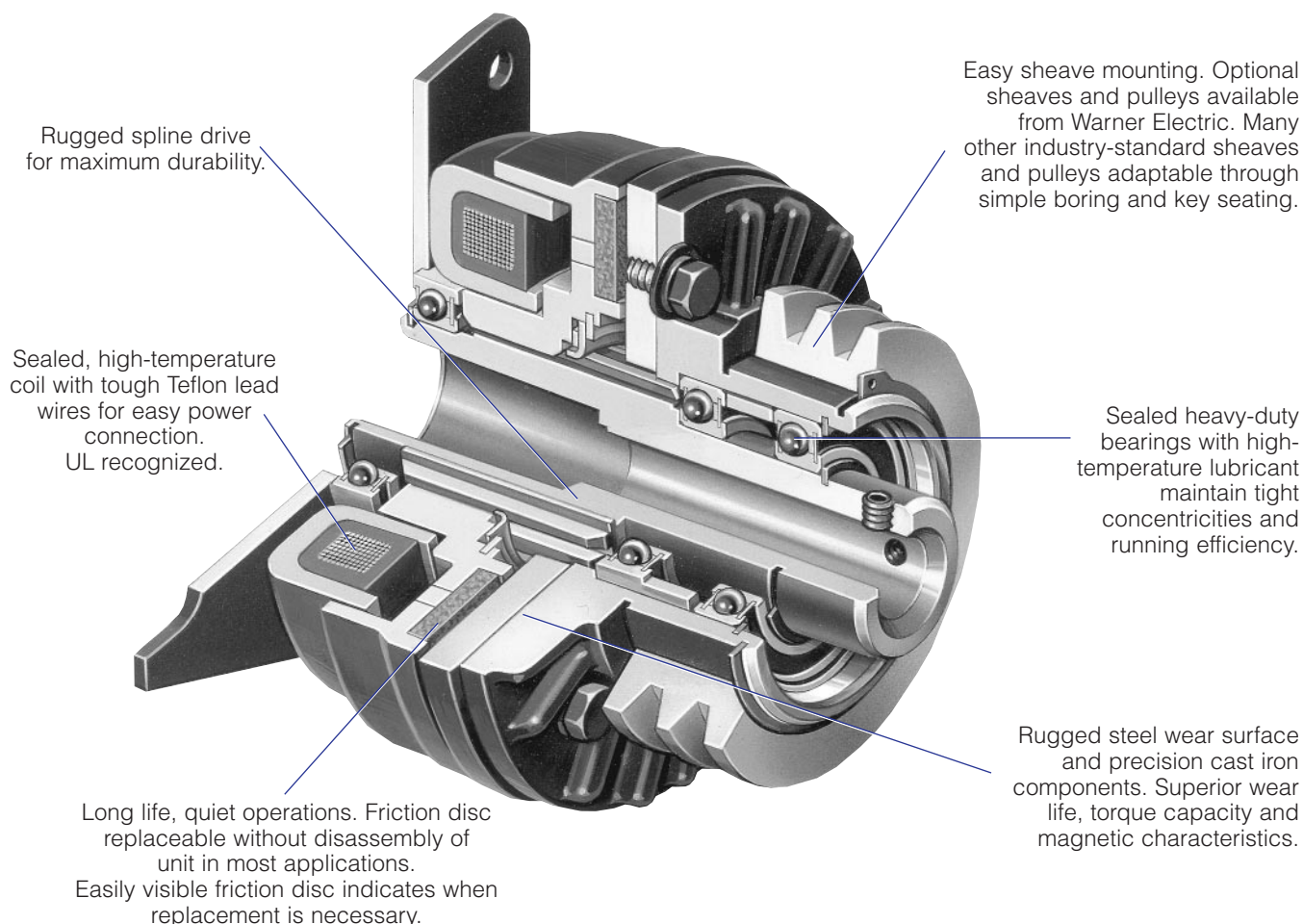

Specifications

Model No.	Mechanical Data			Electrical Data		
	Total Weight (lbs.)	Max Speed (RPM)	Inertia WR ² (lb.ft. ²)	24 VDC		
				Resistance (ohms)	Current (amperes)	Power (watts)
ATTC-25	8	3600	0.048	20.6	1.16	28.0
ATTC-55	18	3600	0.173	19.6	1.22	29.4
ATTC-115	28	3600	0.483	16.5	1.46	34.9

Dimensions

() denotes millimeters

Model	A Max. Dia.	B Max.	C Nom.	D Nom. Dia.	E Max.	F Max.	G Max.	H Max.	J Max Dia.	K Max.	L Max.	M Max.	T Nom.
ATTC-25	3.60 (91.44)	4.39 (111.51)	2.375 (60.33)	1.080 (27.43)	4.748 (120.60)	3.767 (95.68)	3.282 (83.36)	5.11 (129.79)	4.822 (122.49)	1.68 (42.67)	1.003/991 (25.48/25.17)	.715/.703 (18.16/17.86)	.375 (9.53)
ATTC-55	3.95 (100.33)	4.935 (125.35)	2.925 (74.30)	1.40 (35.56)	5.182 (131.62)	3.767 (95.68)	4.032 (102.41)	5.11 (129.79)	6.275 (159.39)	1.817 (46.15)	1.113/1.101 (28.27/27.97)	—	.375 (9.53)
ATTC-115	5.254 (133.45)	5.977 (151.82)	3.102 (78.79)	1.86 (47.24)	6.089 (154.66)	3.767 (95.68)	4.246 (107.85)	10.11 (256.79)	7.906 (200.81)	2.467 (62.66)	1.539/1.523 (39.09/38.68)	—	.375 (9.53)

For replacement parts list and exploded view drawing, see page 161.

Electric Brakes and Clutches

ATT Series – Advanced Technology Brakes and Clutches

Dimensions

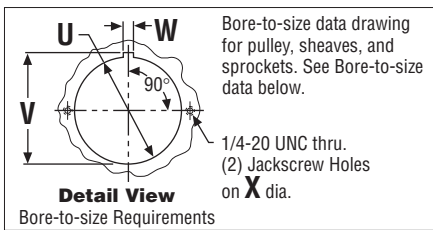
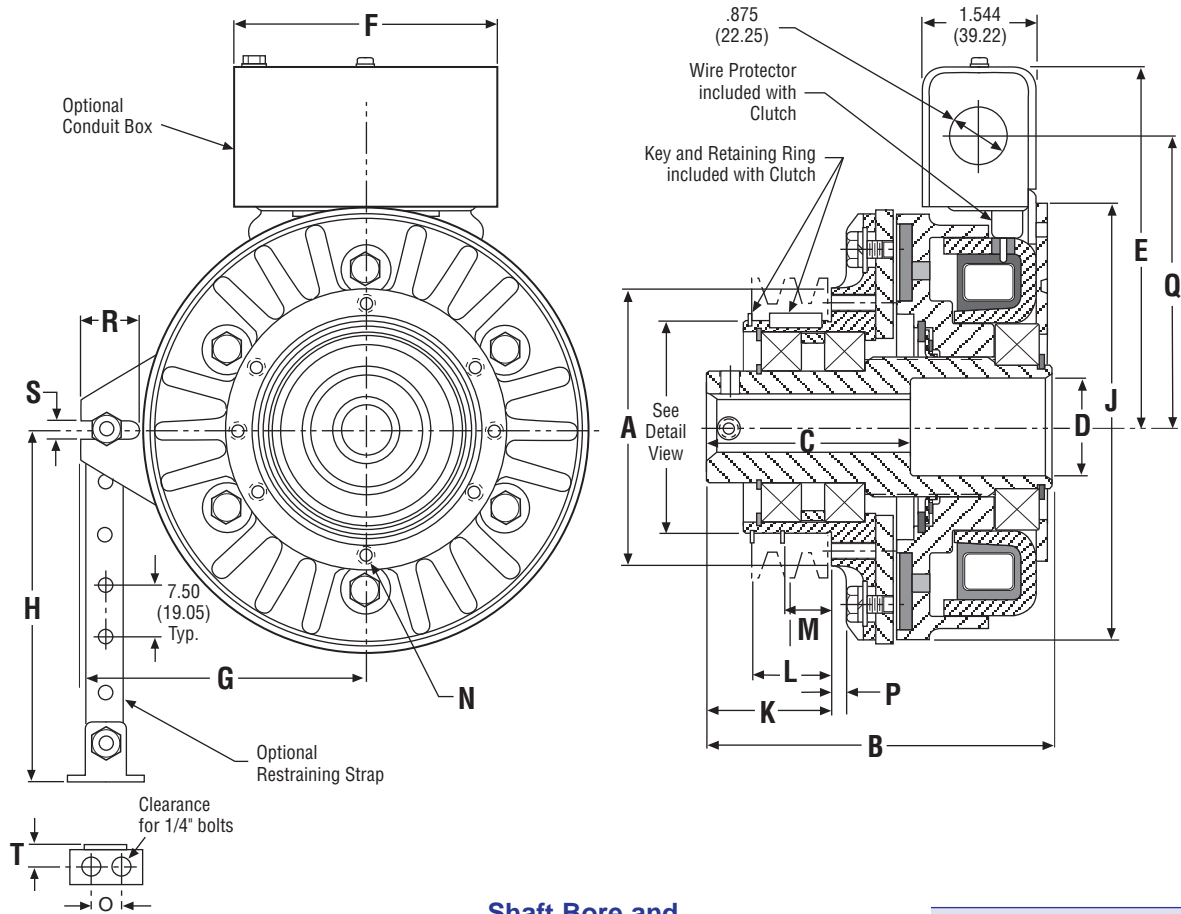

Shaft Bore and Keyway Dimensions

Model	Unit Bore	Key
ATTC-25	.5025 (12.76)	1/8 Sq.
ATTC-55	.5005 (12.71)	1/8 Sq.
ATTC-25	.6275 (15.94)	3/16 Sq.
ATTC-55	.6255 (15.89)	3/16 Sq.
ATTC-25	.7525 (19.11)	3/16 Sq.
ATTC-55	.7505 (19.06)	3/16 Sq.
ATTC-25	.8775 (22.29)	3/16 Sq.
ATTC-55	.8755 (22.24)	3/16 Sq.

Model	Unit Bore	Key
ATTC-55	1.0025 (25.46)	1/4 Sq.
ATTC-55	1.0005 (25.41)	1/4 Sq.
ATTC-55	1.1275 (28.64)	1/4 Sq.
ATTC-115	1.1255 (28.59)	1/4 Sq.
ATTC-115	1.2525 (31.71)	1/4 Sq.
ATTC-115	1.2505 (31.76)	1/4 Sq.
ACCT-115	1.3775 (34.99)	5/16 Sq.
ACCT-115	1.3755 (34.94)	5/16 Sq.
ATTC-115	1.5025 (38.16)	3/8 Sq.
ATTC-115	1.5005 (38.11)	3/8 Sq.

Bore-to-Size Data

Model	No. of Holes	N Thread Size	Max. Depth	Bolt Circle	O Nom.	Q Nom.	R Min.	S Min.
ATTC-25	3	1/4-20	.500	3.00	.500 (12.7)	3.586 (91.08)	.752 (19.08)	.279 (7.09)
ATTC-55	4	1/4-20	.635	3.50	.500 (12.7)	4.156 (105.56)	.722 (18.34)	.265 (6.73)
ATTC-115	4	5/16-18	.830	4.75	.500 (12.7)	4.927 (125.15)	.504 (12.80)	.265 (6.73)

U Bore Dia.	V Keyway Height	W Keyway Width	X Bolt Circle
2.502/2.500 (63.55/63.50)	2.601/2.591 (66.06/65.81)	.1905/.1885 (4.84/4.79)	3.00 (76.20)
3.002/3.000 (76.25/76.20)	3.099/3.089 (78.71/78.46)	.1905/.1885 (4.84/4.79)	3.50 (88.90)
4.002/4.000 (101.65/101.60)	4.127/4.117 (104.83/104.57)	.378/.376 (9.60/9.55)	4.50 (114.30)

For replacement parts list and exploded view drawing, see page 161.